

July Current
20 m/f

<R42-185-0>

Service Manual

AM/FM STEREO RECEIVER

SX-6000/FW

SX-6000

<71H02M41D>

PIONEER®

CONTENTS

1. SPECIFICATIONS	1
2. FRONT PANEL FACILITIES	3
3. CONNECTION DIAGRAM	5
4. CIRCUIT DESCRIPTION	
4. 1 BLOCK DIAGRAM	7
4. 2 ANTENNA CIRCUIT	9
4. 3 FM FRONT END	9
4. 4 FM IF AMPLIFIER	9
4. 5 MUTING CIRCUIT	9
4. 6 MPX DECODER	9
4. 7 AM TUNER	9
4. 8 LOW LEVEL INPUT CIRCUIT	9
4. 9 HEAD AMPLIFIER	9
4.10 HIGH LEVEL INPUTS AND CONTROL CIRCUITS	10
4.11 CONTROL AMPLIFIER, TONE CONTROLS AND FILTERS	10
4.12 POWER AMPLIFIER	10
4.13 POWER SUPPLY	10
5. DISASSEMBLY	
5. 1 WOODEN CASE	11
5. 2 FRONT PANEL	11
5. 3 BOTTOM PLATE	11
5. 4 PARTS, PCB LOCATION	12
6. DIAL CORD STRINGING	13
7. ALIGNMENT PROCEDURES	
7. 1 REQUIRED INSTRUMENTS	14
7. 2 10.7MHz ALIGNMENT	14
7. 3 FM FRONT END ALIGNMENT	15
7. 4 FM MPX DECODER ALIGNMENT	15
7. 5 AM 455kHz ALIGNMENT	16
8. SCHEMATIC DIAGRAM, PCB PATTERNS	17
9. PARTS LIST	31
10. PACKING PROCEDURE AND PARTS	44



1 • SPECIFICATIONS

SEMICONDUCTORS

FET	1
ICs	5
Transistors	40
Diodes	17

POWER AMPLIFIER SECTION

Music Power Output (IHF)	200 Watts (4Ω) 132 Watts (8Ω)
Continuous Power Output (each channel driven)	67W/67W (4Ω) 54W/54W(8Ω)
Continuous Power Output (both channel driven)	45W + 45W (4Ω) 40W + 40W (8Ω)
Power Output in the range of 20Hz to 20kHz (both channel driven)	36W + 36W (8Ω Harmonic Distortion Less than 1%)
Harmonic Distortion	Less than 1% (Continuous power output) Less than 0.2% (50W/50W, 8 Ω)
Intermodulation Distortion	Less than 1.5% (Continuous power output) Less than 0.4% (50W/50W, 8 Ω)
Power Bandwidth (IHF)	10Hz to 80kHz/8Ω (Harmonic Distortion Less than 1%)
Frequency Response	5Hz to 100kHz, ±2dB
Input Sensitivity/Impedance (1kHz, Continuous power output)	500mV/50kΩ
Speakers	4 to 16Ω (A, B, C)
Damping Factor	65/8Ω (1kHz)
Center Channel Output	520mV

PREAMPLIFIER SECTION

Output Voltage	500mV (Rated output), 1.4V (Max)
Harmonic Distortion	Less than 0.1%
Frequency Response	8Hz to 80kHz, ±3dB
Input Sensitivity/Impedance (1kHz, for rated output)	PHONO 1 2.4mV/50kΩ PHONO 2 2.4mV/50kΩ MIC 4mV/50kΩ AUX 1, 2 210mV/100kΩ TAPE MONITOR 1, 2 210mV/100kΩ
Recording Output	TAPE REC 1, 2 (Pin jack) 210mV TAPE REC (DIN connector) 37mV
BASS Control	-12.5dB, +10dB/100Hz
TREBLE Control	-10dB, +10.5dB/10kHz
LOW Filter	-6.5dB/50Hz (6dB/oct.)
HIGH Filter	-6.5dB/10kHz (12dB/oct.)
Equalization Curve	PHONO: RIAA S.T.D.
Loudness Contour	+11dB/100Hz, +6dB/10kHz with Volume Control set at -40dB position.
Muting	-20dB
Hum and Noise (IHF)	PHONO More than 80dB AUX More than 90dB

FM TUNER SECTION

Frequency Range	87.5MHz to 108MHz
Usable Sensitivity (IHF)	1.8μV
Capture Ratio (IHF)	1.5dB
Selectivity (IHF)	More than 40dB
Image Rejection	More than 85dB (98MHz)
IF Rejection	More than 88dB (90MHz)
Spurious Rejection	More than 85dB (98MHz)
AM Suppression	42dB
Signal-to-Noise Ratio	65dB
Harmonic Distortion	Mono: Less than 0.3% (100% Mod.) Stereo: Less than 0.5% (100% Mod.)
Tuning Indicator	Signal strength type and Center Tuning type
Muting	Switchable to ON-OFF
Stereo Separation	More than 40dB (1kHz)
Sub Carrier Suppression	More than 40dB
Antenna Input	Impedance 300Ω balanced and 75Ω unbalanced.

AM TUNER SECTION

Frequency Range	525kHz to 1,605kHz
Usable Sensitivity (IHF)	9μV
Selectivity (IHF)	More than 30dB
Image Rejection	More than 80dB (1,000kHz)
IF Rejection	More than 75dB
Signal-to-Noise Ratio	More than 50dB
Antenna	Built-in Ferrite Loopstick Antenna

MISCELLANEOUS

Power Requirements	110V, 120V, 130V, 220V and 240V. (Switchable)
	50 to 60Hz
Power Consumption	250W (Max)
Dimensions (overall)	17- ⁹ / ₁₆ in/470mm (width) 6- ⁷ / ₁₆ in/172mm (height) 12- ¹¹ / ₁₆ in/340mm (depth)
Weight	Without package 29lb/13.2kg With package 35lb, 3oz/16kg
Furnished Accessories	FM T-type Antenna 1 Pin Plug 4 Speaker Plug 6 Fuse (1.5A) 1 Fuse (3A) 2 Polishing Cloth 1 Operating Instructions 1

• Specifications and design subject to possible modification without notice due to improvements.

2 • FRONT PANEL FACILITIES

POWER
Two positions, ON and OFF.

SPEAKER SWITCH

Speaker system selector switch

A: Sound is reproduced from the speaker system connected to the SPEAKER OUTPUT A socket.

OFF: Speakers stop sounding.

This position is selected when using a pair of stereo headphones.

B: The speaker system connected to the SPEAKER OUTPUT B socket is put in operation.

C: The speaker system connected to the SPEAKER OUTPUT C socket is put in operation.

A + B: The speaker systems connected to SPEAKER OUTPUT A and B sockets are put in operation.

A + C: The speaker systems connected to SPEAKER OUTPUT B and C sockets are put in operation.

PHONES JACKS

These phones jacks for stereo headphone(s).

The two jacks (1, 2) are available for connection with two stereo headphones.

BASS

Turn this knob to the right (clockwise) to increase bass tones, to the left (counterclockwise) to decrease them. Set the knob at its center position for flat response.

TREBLE

Use of this knob is similar to that of the BASS knob.

FILTER

LOW: Use this filter to cut out low-frequency interference, such as motor rumbling or hum.

HIGH: Use this filter to cut out high-frequency interference, such as that from fluorescent lights.

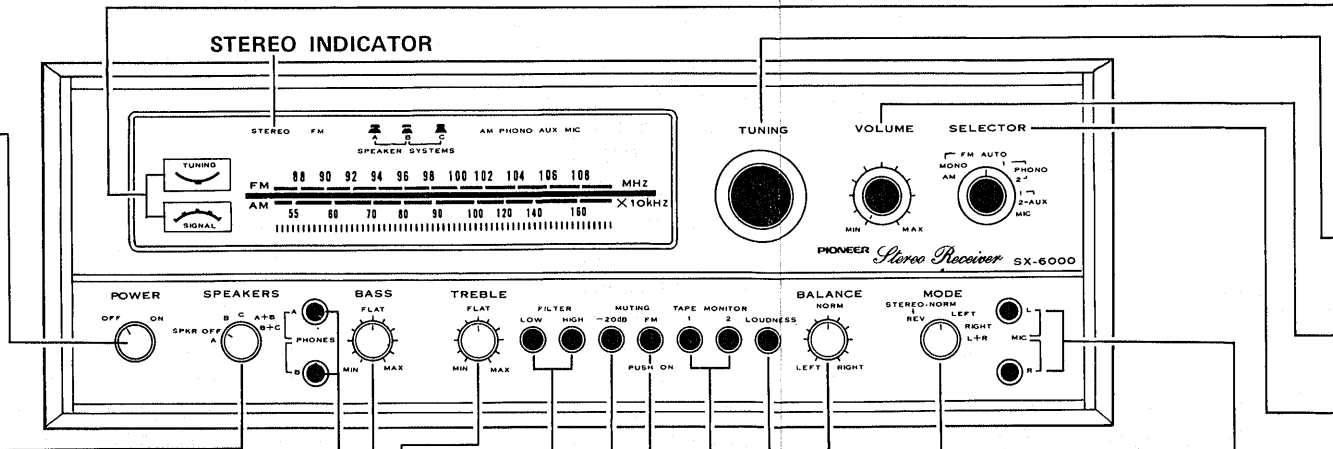

TUNING METERS

When selecting an AM broadcast, tune so that the dial pointer of the lower meter deflects as far to the right as possible.

For an FM broadcast, use the lower meter in the same way. Precision FM tuning is also possible by adjusting so that the dial pointer of the upper meter is centered.

TUNING

This knob is used to locate AM or FM stations. Watch the deflection of the pointer(s) of the tuning indicator for more precise tuning.

VOLUME

To increase the volume, turn it to the right (clockwise).

SELECTOR

This switch is for choosing the program source.

AM:	AM reception
FM MONO:	FM monophonic reception only.
FM AUTO:	FM reception by automatic switching for either stereo or monophonic program.
PHONO 1:	For playing records on a turntable connected to the PHONO 1 terminals.
PHONO 2:	Same as above, for PHONO 2 terminals.
AUX 1:	For playing signals fed to the AUX 1 terminals.
AUX 2:	Same as above, for AUX 2 terminals.
MIC:	For reproduction through a microphone.

MIC JACKS (L,R)

Connect the plug attached to the microphone lead to these jacks. A high-impedance, dynamic-type microphone with a standard plug should be used. A selection of high-performance dynamic microphones is available from Pioneer.

MODE SWITCH

Controls the stereo and mono output functions of the unit as follows:

REV:	Stereo, with right and left channel signals reversed.
STEREO NORM:	Normal stereo
LEFT:	Left channel signal fed to both left and right speakers.
RIGHT:	Right channel signal fed to both left and right speakers.
L + R:	Left and right channel signals mixed, then fed to both left and right channel speakers.

BALANCE CONTROL

Used to adjust the stereophonic balance between left and right channels. Turning to the left strengthens the left channel sound; to the right, the right channel.

LOUDNESS

At reduced volume the ear's sensitivity to extremely low and high frequencies is reduced. This switch compensates for that phenomenon by emphasizing these frequencies. At normal or high volumes this switch should be kept off.

TAPE MONITOR SWITCHES (1 and 2)

These switches are set to ON for checking the recording conditions or for playback with tape decks.

1. This switch is set to ON for monitoring recording in progress or for playback with a tape deck connected to TAPE 1 MON terminals and TAPE 1 REC terminals or TAPE REC/P.B. connector.

2. This switch is set to ON for checking the recording conditions or for playback with a tape deck connected to TAPE 2 MON terminals and TAPE 2 REC terminals.

NOTE: For a record playback or listening to broadcasts, leave these switches set to the OFF position. With the switches set to ON, speakers will not operate.

FM MUTING

This switch is used to suppress much noise between FM stations when tuning. In a fringe area, however, this switch should be kept off because it may suppress the desired station signal at the same time.

MUTING SWITCH

Pushing this switch to the -20dB position decreases the volume by 20dB instantly. Setting it to the OFF position restores the volume to normal.

3 • CONNECTION DIAGRAM

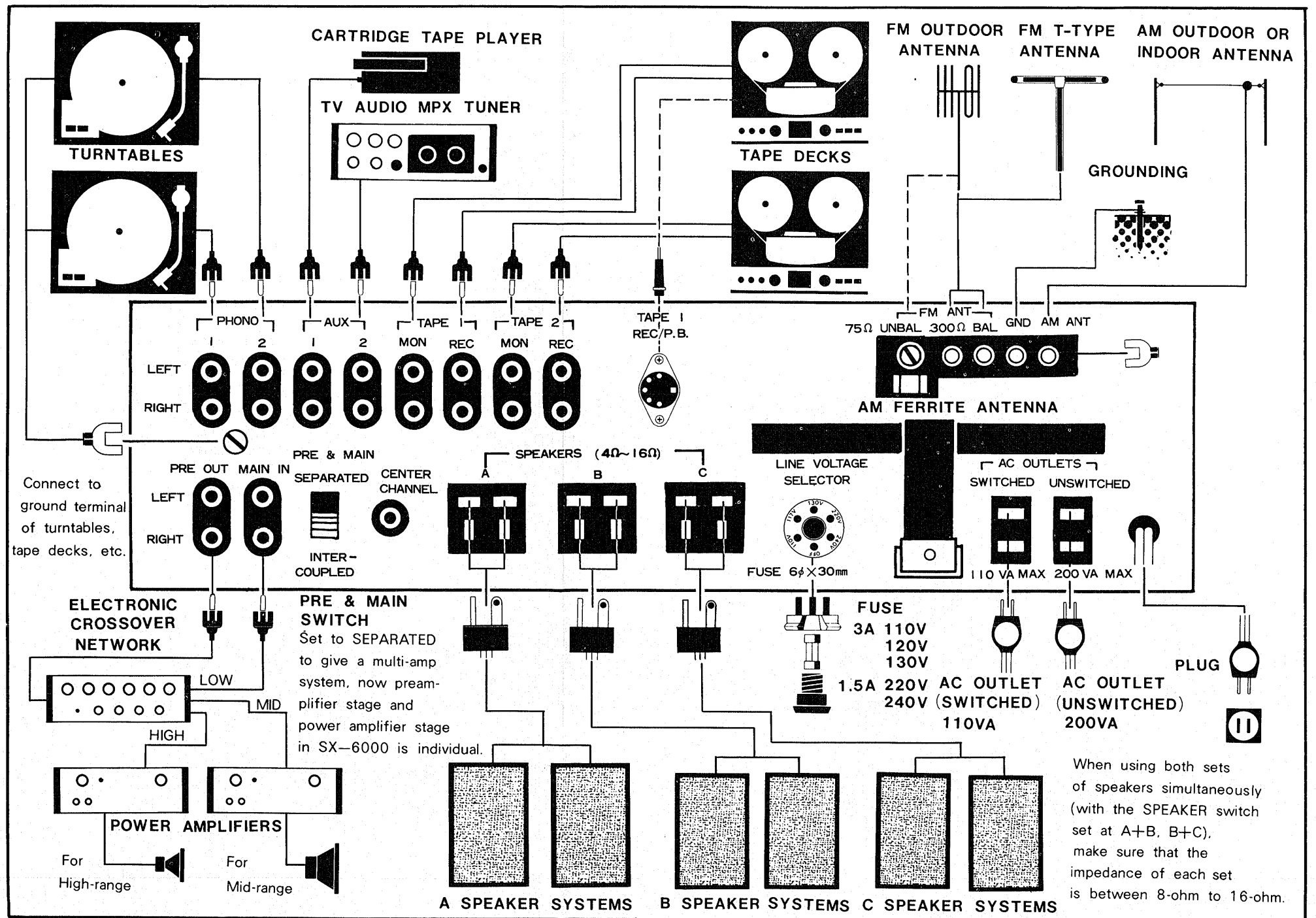

4 • CIRCUIT DESCRIPTION

4.1 BLOCK DIAGRAM

As shown in the block diagram, SX-6000 comprises the following stages and circuits.

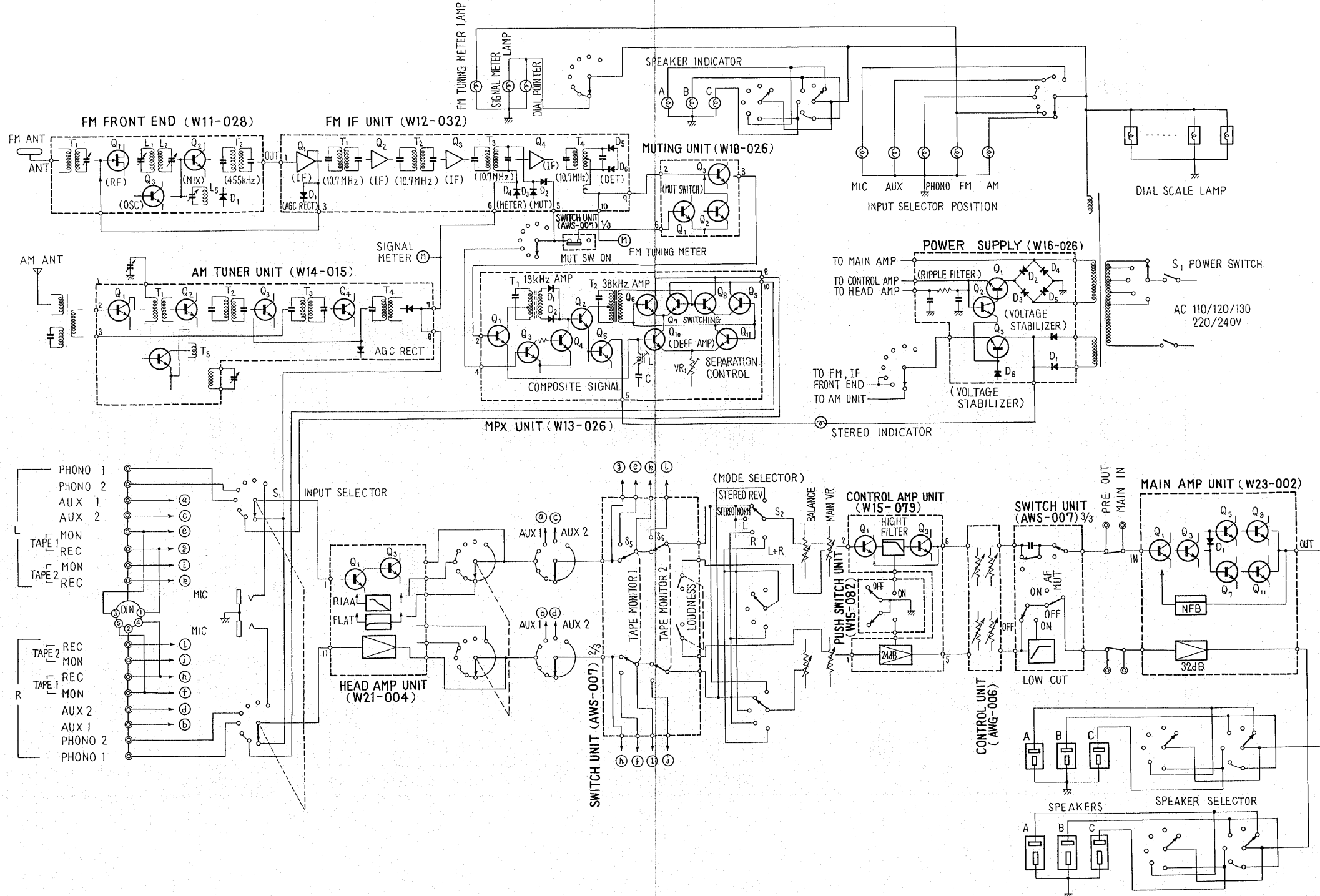

4-2 ANTENNA CIRCUIT

FM: The antenna signal enters the receiver through the antenna terminals of 300Ω (for ribbon-type antenna feeder) or 75Ω (for coaxial antenna cable).

AM: The ferrite loopstick antenna coil serves as inductance for the top tuning circuit.

4-3 FM FRONT END

The front end consists of a tuned RF amplifier Q1, converter Q2, and split-type heterodyne oscillator Q3. The oscillator frequency is varied from 98.2 to 118.7MHz and serves as source for the converter, Q2. There, the amplified 87.5 to 108MHz RF input signal is mixed with the 98.2 to 118.7MHz oscillator signal to produce an IF of 10.7MHz. The RF amplifier utilizes an FET (Q1), and AGC voltage is applied to the gate of Q1. This control voltage is obtained from the IF amplifier PCB through a rectifier circuit.

4-4 FM IF AMPLIFIER

The 10.7MHz output from T2 of the front end is supplied to the IC, Q1. The output from this amplifier goes to the next IC, Q2, and produces the AGC voltage at pin 3 through D1.

Q2 to Q4 and the tuned circuits of T2, T3 and T4 provide amplification and limiting of the 10.7MHz IF signal. The trigger voltage for the muting circuit detector output is taken from the 3rd stage (T3) output. The final stage on this circuit board is the discriminator, a ratio detector. Its output includes, in the case of an MPX stereo program, the L+R, L-R and 19kHz pilot signals.

4-5 MUTING CIRCUIT

This circuit consists of a Schmitt circuit Q1 and Q2, and a gate circuit Q3. Detector output from pin 5 of the IF PCB enters Q1 through the muting switch on the switch unit, PCB No. AWS-007.

When tuned, the detector output at pin 5 of the IF amplifier PCB has positive DC voltage, which makes Q1 conductive, depending on its potential.

This trigger voltage alternately switches the Schmitt circuit Q1 and Q2 on and off. This operation causes a voltage variation at the collector of Q2 and opens and closes the gate circuit Q3 when the muting switch is set to ON. The output of the gate circuit is taken from the collector side of Q3 because there is no output to the MPX circuit when Q3 is off. +12V enters the base of Q1 through muting switch and resistor, but the output from the Q3 when the muting switch is OFF.

4-6 MPX DECODER

The composite signal of an FM MPX broadcast, containing L+R, L-R and 19kHz pilot signals, is supplied from the muting PCB to Q1 of the MPX UNIT. This stage serves as a tuned amplifier for 19kHz and as an impedance changer to match the supplied signal to the switching circuit (Q6 to Q11). The primary winding of the collector side of Q1 is tuned to 19kHz, the secondary winding is connected to the full-wave rectifier D1, D2. The 19kHz pilot carrier is converted into a 38kHz ripple current of double frequency. Q4 operates as a class B amplifier for this 38kHz ripple signal, and a 38kHz tuned transformer eliminates harmonics from the 38kHz ripple signal, to obtain a clean sine wave for switching L and R. The Q2, Q3 circuit functions as a sensor that detects whether a broadcast is stereophonic or monophonic (when the selector switch is at FM AUTO position).

IC Q6 works as an amplifier to cancel out crosstalk. The 330Ω VR1 is for adjustment of channel separation.

The output from the switching circuit enters the audio amplifier section through a low pass filter.

4-7 AM TUNER

The AM tuner section employs one RF amplifier, a heterodyne oscillator, two 455kHz IF amplifiers and a detector. Except for the different frequency, the method of conversion to 455kHz IF is the same as in the FM front end.

AGC voltage, taken from the collector of Q4 through diode, is delivered to Q3 and back to Q2 converter base through Q1. Q1 operates as a DC amplifier to obtain sufficient AGC.

4-8 LOW LEVEL INPUT CIRCUIT

Low level signals such as outputs from phono cartridge or microphone are supplied into the PHONO 1 & 2 and MIC input jacks.

Program sources are selected by the input selector, S1.

4-9 HEAD AMPLIFIER

The head amplifier is contained on the W21-004 PCB, consisting of two voltage amplifiers. The overall negative feedback loop circuit for equalization is connected between the collector of Q3 and emitter of Q1.

Equalization characteristics are: RIAA playback for PHONO, flat response for microphone.

4-10 HIGH LEVEL INPUTS AND CONTROL CIRCUITS

High level inputs such as AUX 1 & 2 and radio reception are also selected by S1. Input from tape deck and recording output signal (a head amplifier output or a direct output from a high level input) are switched by TAPE MONITOR switches S5 and S6, respectively. The selected signal then passes to mode switch S2, balance and volume controls.

4-11 CONTROL AMPLIFIER, TONE CONTROLS AND FILTERS

This stage, consisting of two transistors, is embodied on PCB No. W15-079.

NFB is applied to the top stage transistor (emitter) to obtain stable, high impedance under all conditions. The output from the collector of Q1 passes to base of Q3 through 6dB/oct. high cut filter circuit. The output from Q3 passes to the tone controls and low cut filter circuits.

The tone control characteristics, i.e. treble boost and cut, bass boost and cut, are controlled by RC networks.

The low cut filter design uses switchable RC factors, and its characteristic is 6dB/oct.

4-12 POWER AMPLIFIER

The power amplifier circuit is assembled in PCB No. W23-002. It consists of six transistors (Q1, Q3, Q5, Q7, Q9 and Q11) for each channel. Overall NFB is applied from output to the emitter of Q1, thus improving distortion and frequency response. Transistors Q3, Q5, Q7, Q9 and Q11 are all direct coupled, stabilizing the circuit by applying NFB in both AC and DC. The thermistor against fluctuations of ambient temperature stabilizes temperature characteristics.

4-13 POWER SUPPLY

Q1 and Q2 are a voltage regulator, supplying low-ripple rectified current to the audio amplifier sections such as head amplifier and control amplifier.

The other regulated voltage for the tuner section (FM front end, FM IF amplifier, muting circuit, MPX decoder and AM tuner) is obtained from the other power transformer taps via a full-wave rectifier through voltage regulator Q3. All parts except the filter capacitor and power transformer are located on PCB No. W16-026.

5 • DISASSEMBLY

5.1 WOODEN CASE

Remove the 4 screws from the bottom of the wooden case. Pull the case backward off the receiver housing.

5.2 FRONT PANEL

Pull off all knobs, then remove nut and washer from shaft and remove 5 screws from front panel as illustrated in Fig. 1. The front panel can be removed.

5.3 BOTTOM PLATE

The bottom plate can be removed after loosening the 6 screws.

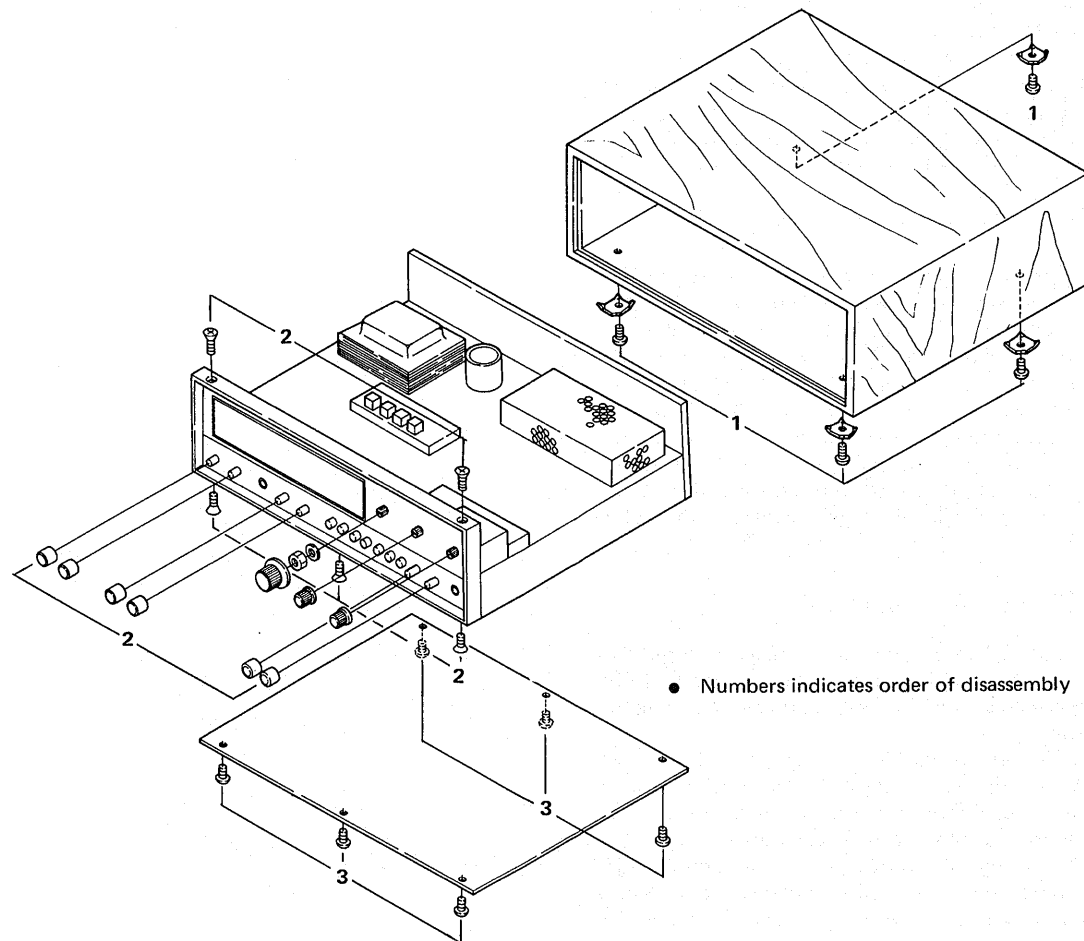
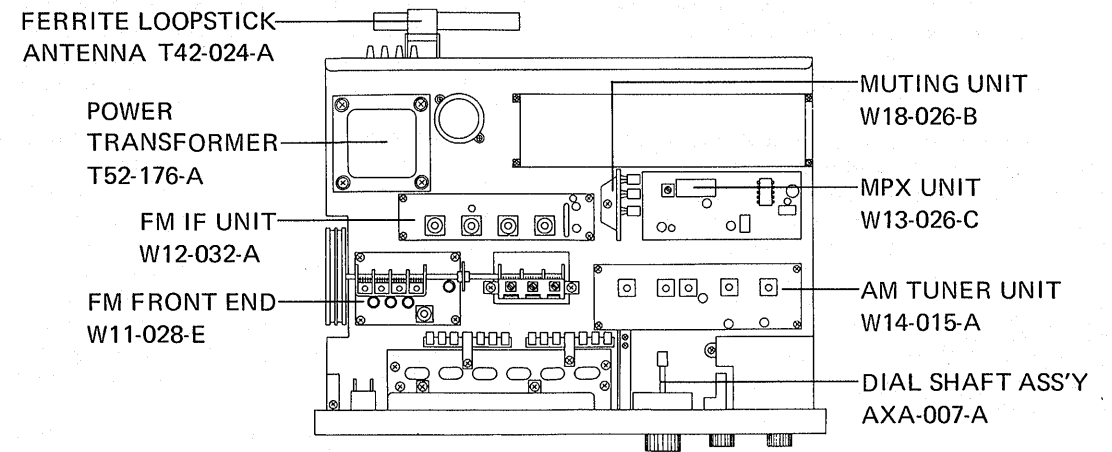

Fig. 1

5.4 PARTS, PCB LOCATION

TOP VIEW



BOTTOM VIEW

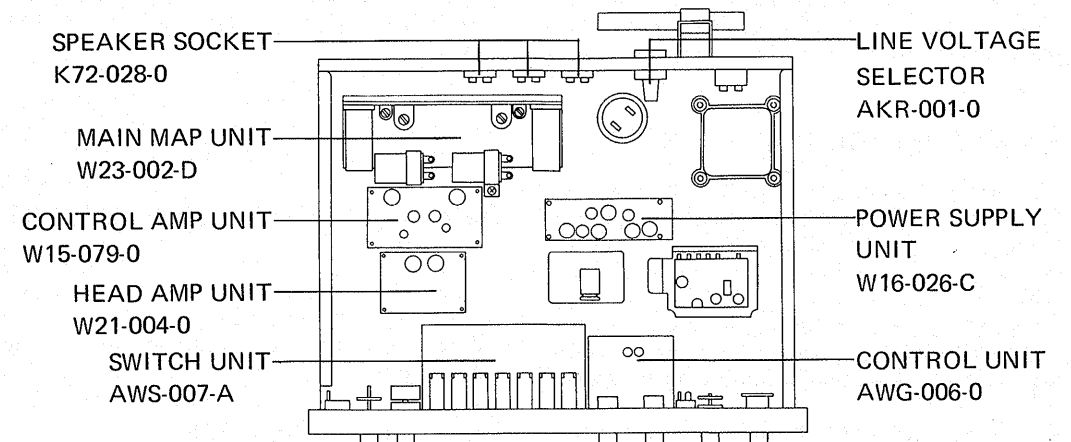

6 • DIAL CORD STRINGING

1. Set the tuning capacitor to minimum capacitance.
2. Tie one end of string on tuning pulley.
3. Pull string around small pulley (A), then fasten string to dial pointer.
4. Lead string around small pulley (B), then wind 3 turns around tuning shaft.
5. Lead string around small pulleys C and D, then return to tuning pulley.
6. Wind string $\frac{1}{2}$ turn around tuning pulley.
7. Finally, tie end of string to remaining side of spring on tuning pulley.
8. Tune receiver to high end. Fasten dial pointer to string so that it indicates high end on dial scale.

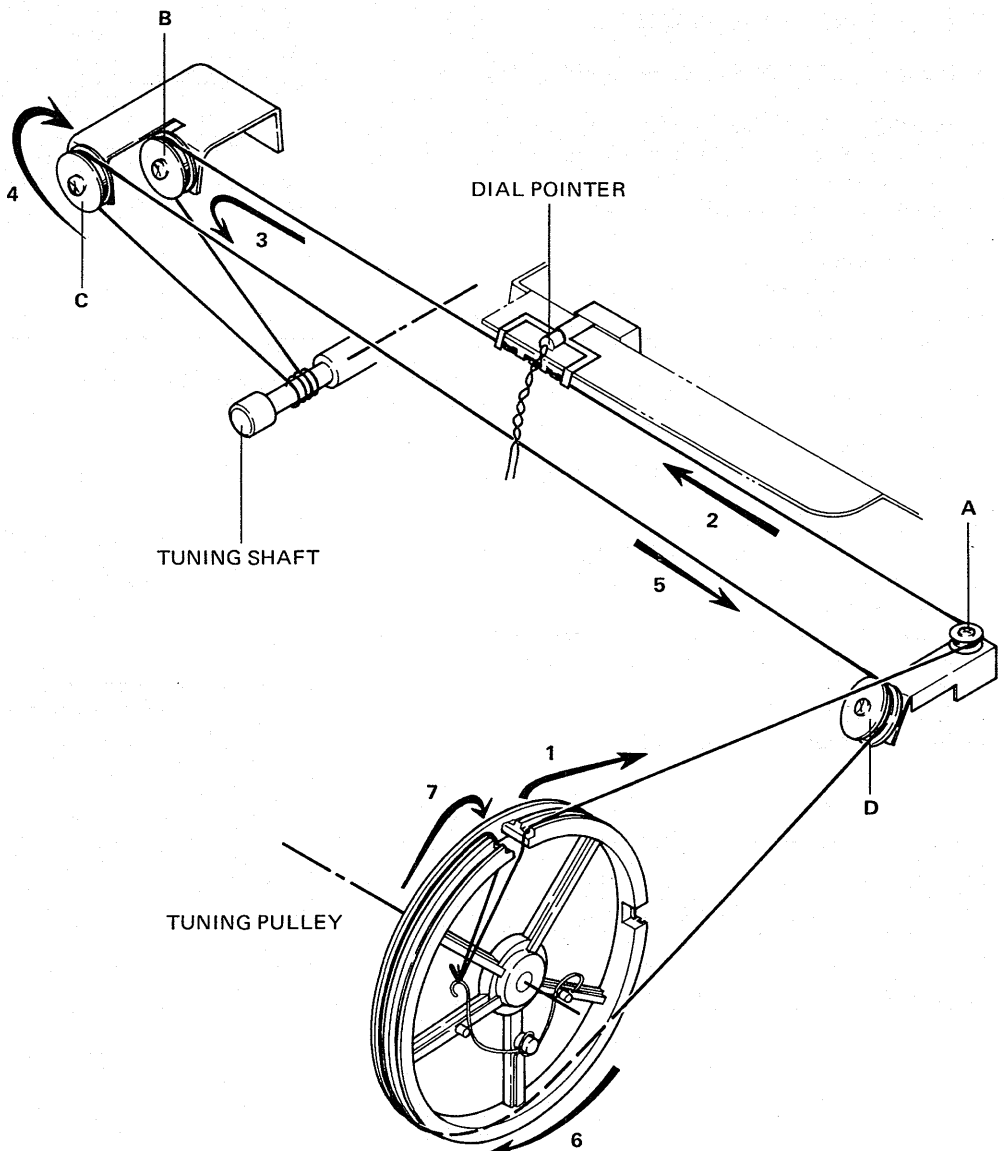

Fig. 2

7 • ALIGNMENT PROCEDURES

The following alignments are required only in very rare cases and should never be attempted unless absolutely necessary. Only non-metallic tools must be used.

7.1 REQUIRED INSTRUMENTS

- Sweep generator
- Oscilloscope
- AC VTVM
- AM/FM signal generator.
- FM multiplex signal generator, preferably with RF output.

7.2 10.7MHz ALIGNMENT

- a) Set the SELECTOR switch to FM MONO position.
- b) Confirm +B voltage and current for 12V \pm 1V which should be 31mA to 44mA at pin 4 of the IF PCB.
- c) Disconnect lead from pin 1 (input).
- d) Connect 10.7MHz sweep generator to pin 1 (hot) and 2 (ground).
- e) Connect vertical scope input to pin 6.
- f) Align cores of T1, T2 and T3 for maximum gain and symmetry to obtain scope pattern as in Fig. 3.
- g) Raise generator output gradually to 80dB (10mV), repeat step (f) for each output level, if necessary.
- h) Disconnect one side of C20. Disconnect oscilloscope.
- i) Connect scope input to pin 10.
- j) Set generator output back to 55dB (500 μ V).
- k) Adjust bottom core of T4 for maximum gain and linearity.
Adjust top core so that center frequency mark is located on zero axis, as shown in Fig. 4.
- l) Reconnect C20.
- m) Reconnect input lead to pin 1.

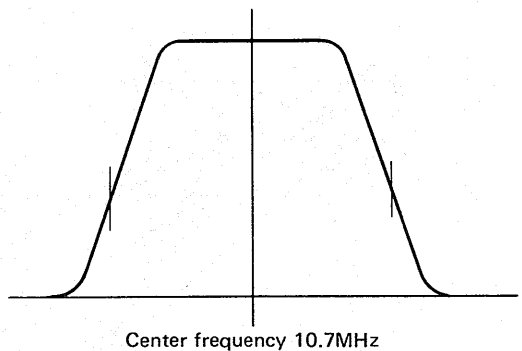
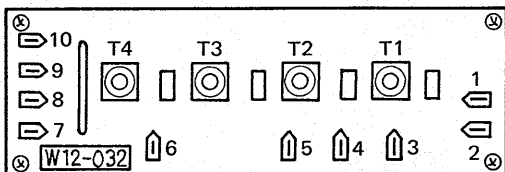

Fig. 3

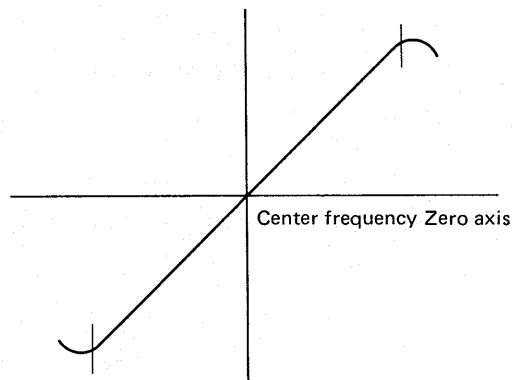
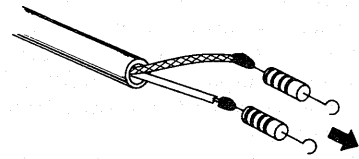

Fig. 4

7-3 FM FRONT END ALIGNMENT

- a) Set the SELECTOR switch to FM MONO position.
- b) Confirm +B current (drain 5mA -19mA).
- c) Connect FM signal generator output to 300Ω antenna input. Insert a 150Ω resistor in series with each lead, as shown in Fig. 5.
- d) Connect AC VTVM to either L or R of TAPE REC jacks on rear panel.
- e) Adjust generator for 400Hz, 100% modulation.
- f) Adjust generator frequency and tuning dial to 90MHz. During the following adjustments, keep the generator output as low as possible.
- g) Adjust L5 core first, then adjust cores of L1, L2, T1 for maximum reading on VTVM and so that tuning meter indicates center position.
- h) Set generator frequency and tuning dial to 106MHz.
- i) Adjust trimmer capacitor CT4 first, then adjust CT1, CT2, CT3 for maximum reading on VTVM and so that tuning meter indicates center position.
- j) Repeat these alignments several times until satisfactory readings are obtained.
- k) Finally, adjust T2 cores for maximum reading on VTVM.

From generator



To 300Ω Antenna terminals

Fig. 5

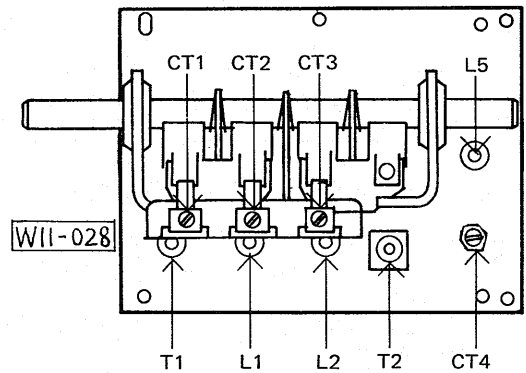

7-4 FM MPX DECODER ALIGNMENT

- a) Set SELECTOR switch on front panel to FM AUTO position.
- b) Connect RF output of FM multiplex signal generator to 300Ω antenna input, with a 150Ω resistor in each lead as shown in Fig. 5.
- c) Adjust MPX generator as follows: *vs:*

Signal mode	Deviation
L+R (main)	40.5kHz
19kHz (pilot)	7.5kHz
- d) Connect AC VTVM to TAPE REC jack on rear panel.
- e) Set generator signal mode to L-R (sub), adjust core of L1 (located on MPX PCB) to obtain maximum reading on VTVM.
- f) Set generator signal mode to L. Adjust VR1 (located on MPX PCB) for minimum crosstalk on R channel TAPE REC output.
- g) Set generator signal mode to R. Repeat above adjustment for minimum crosstalk on L channel.

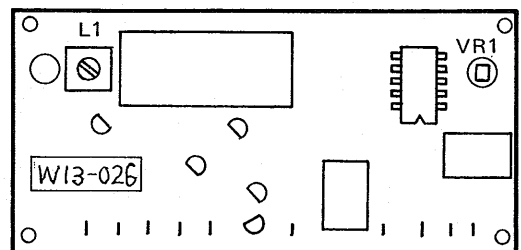

7.5 AM 455kHz ALIGNMENT

- Set SELECTOR switch on front panel to AM position.
- Connect 455kHz sweep generator to test-point 12 through 0.1 μ F capacitor. Adjust generator output level to 60dB (1mV).
- Connect vertical oscilloscope input to TAPE REC jack.
- Set tuning dial to high end position.
- Adjust cores of T3, T4 and T5 for maximum gain and symmetrical pattern on oscilloscope.

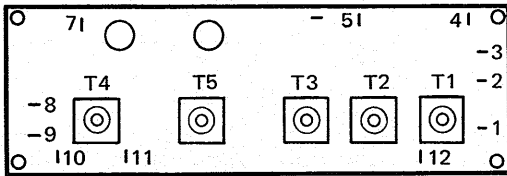

7.6 AM TRACKING ALIGNMENT

- Set SELECTOR switch to AM position.
- For this alignment, bottom plate must be installed.
- Set signal generator to AM function, 30% modulation with 400Hz. Connect loop antenna to generator RF output and place near receiver's ferrite core antenna. See Fig. 6.
- Connect VTVM to TAPE REC jack.
- Keep generator as low as possible for minimum VTVM reading.
- Tune generator and receiver to 600kHz. Adjust core of T2 on AM circuit PCB for maximum VTVM reading, then adjust core of T1 and ferrite antenna.
- Re-tune generator and receiver to 1,400kHz.
- Adjust trimmers on variable capacitor indicated in Fig. 7 to obtain maximum VTVM reading.

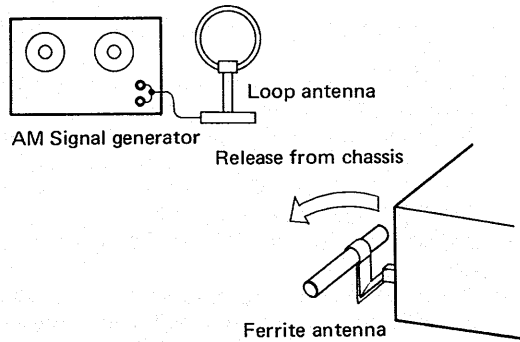
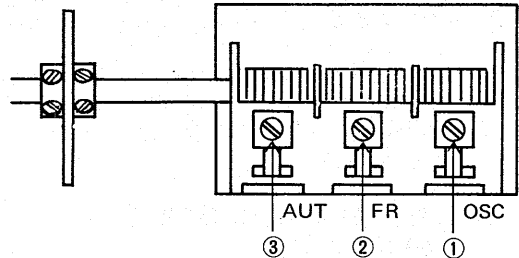

Fig. 6



- Numbers indicate order of alignments.

Fig. 7

8 • SCHEMATIC DIAGRAM, PCB PATTERNS

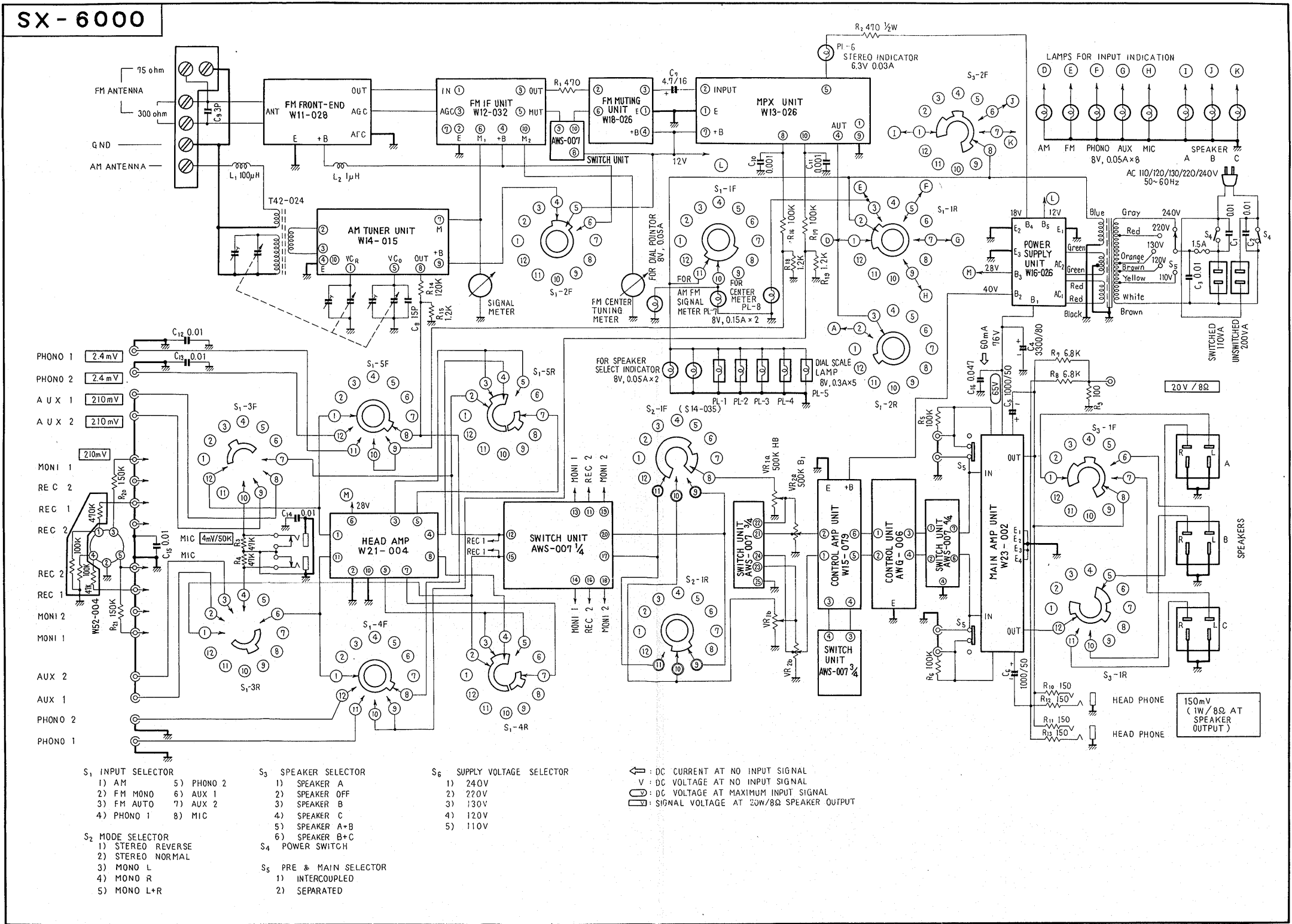

FM FRONT END (W11-028)

FM FRONT-END
W11-028

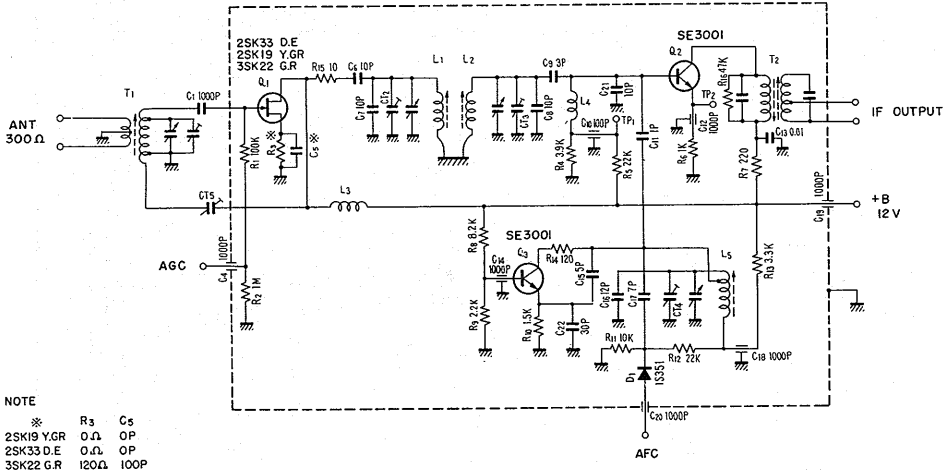

FM IF UNIT (W12-032)

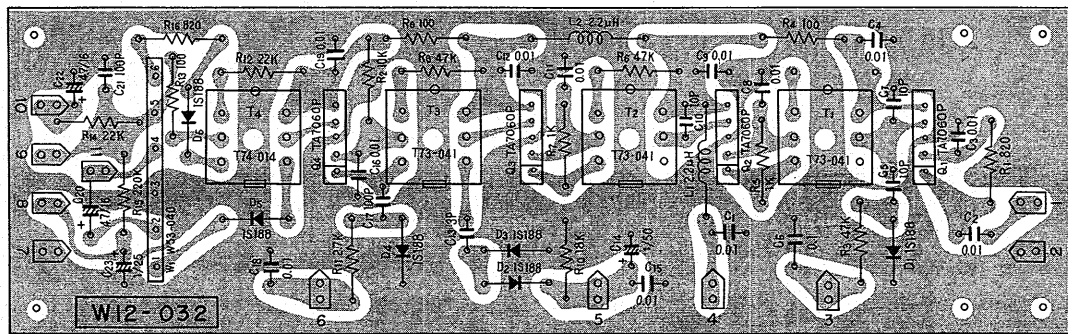
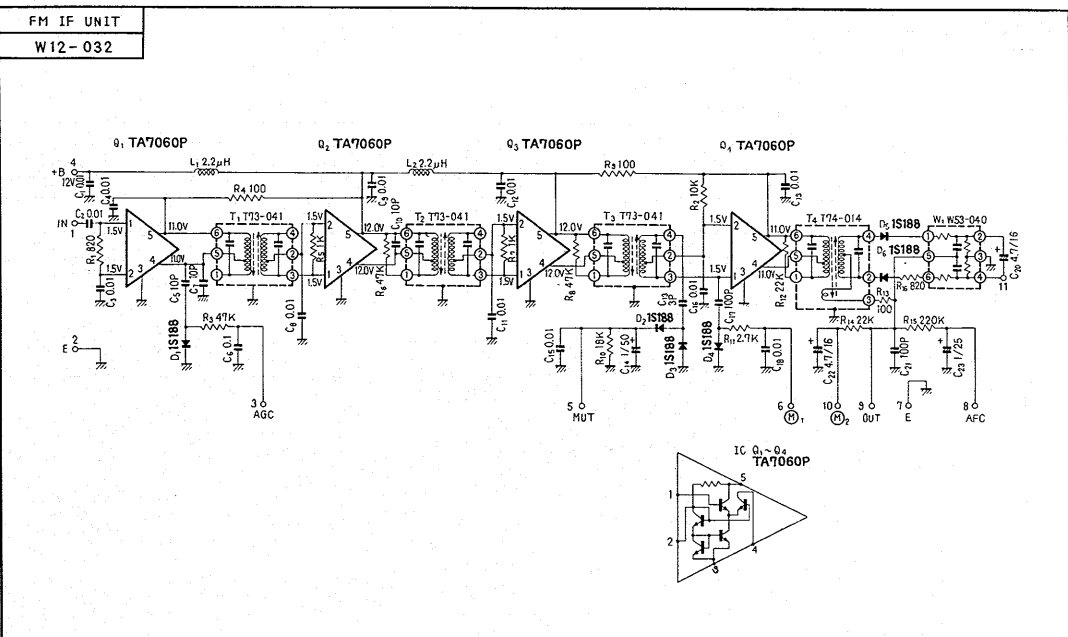

MPX UNIT (W13-026)

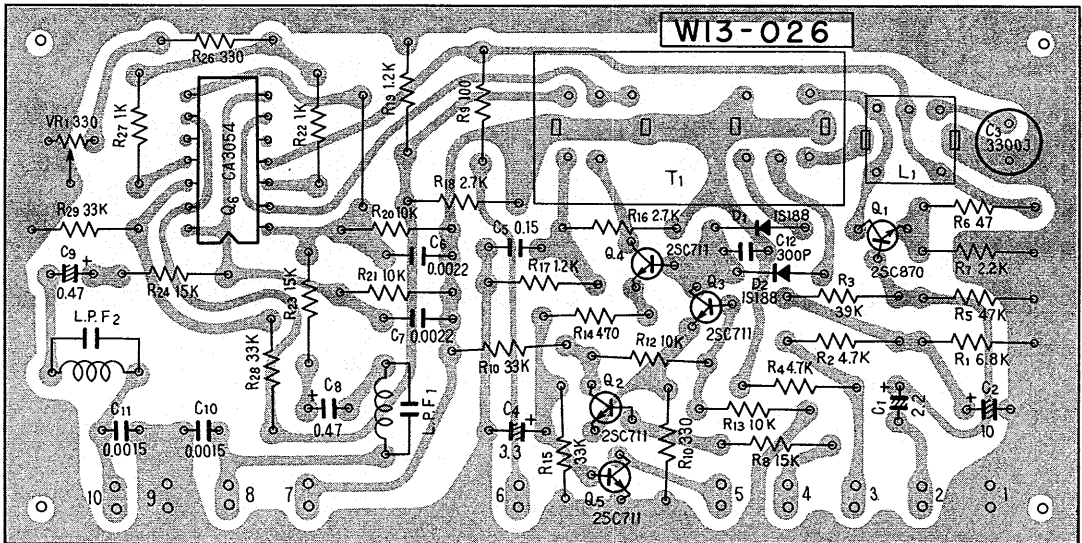
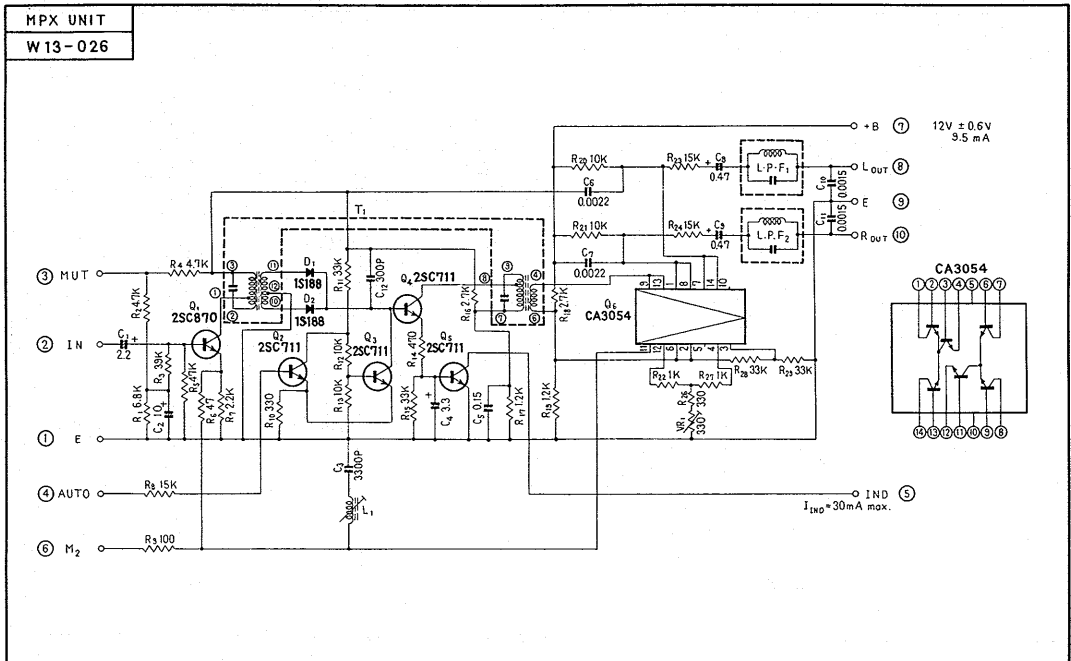

AM TUNER UNIT (W14-015)

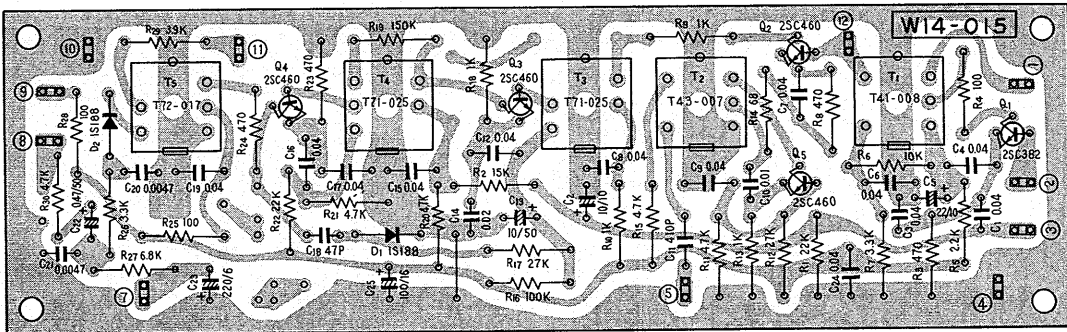
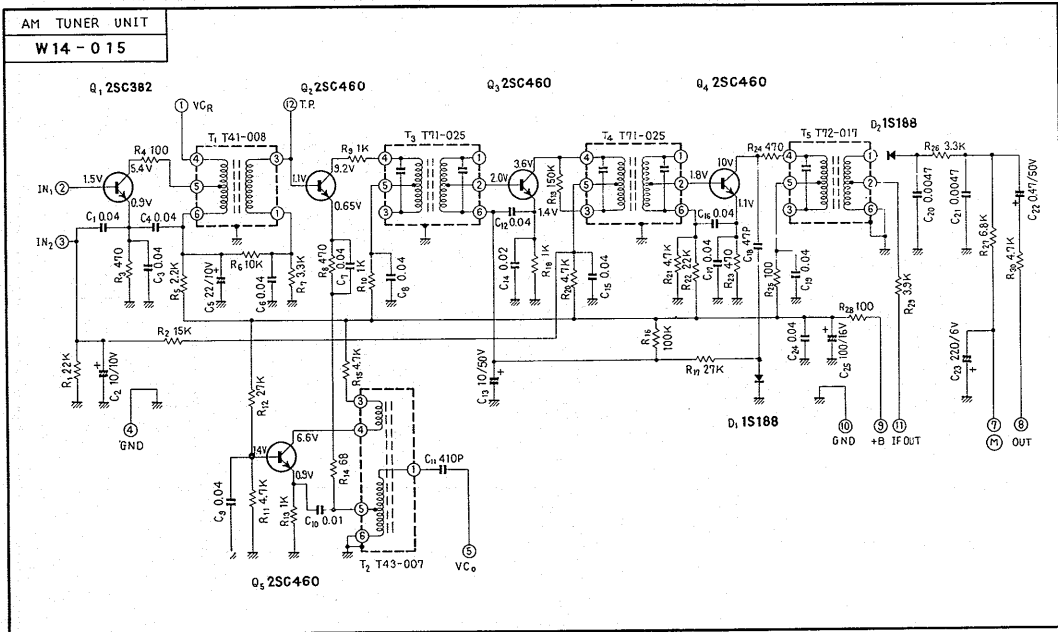

MUTING UNIT (W18-026)

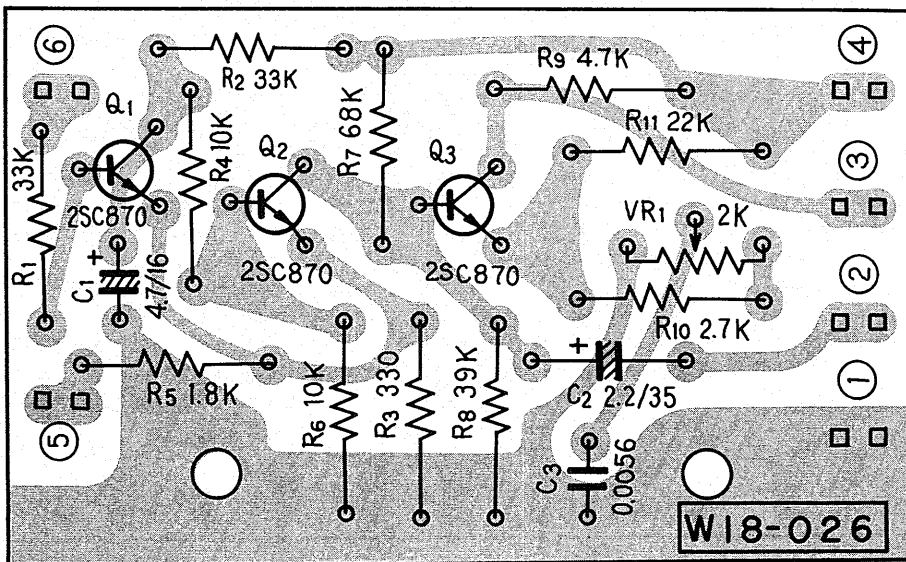
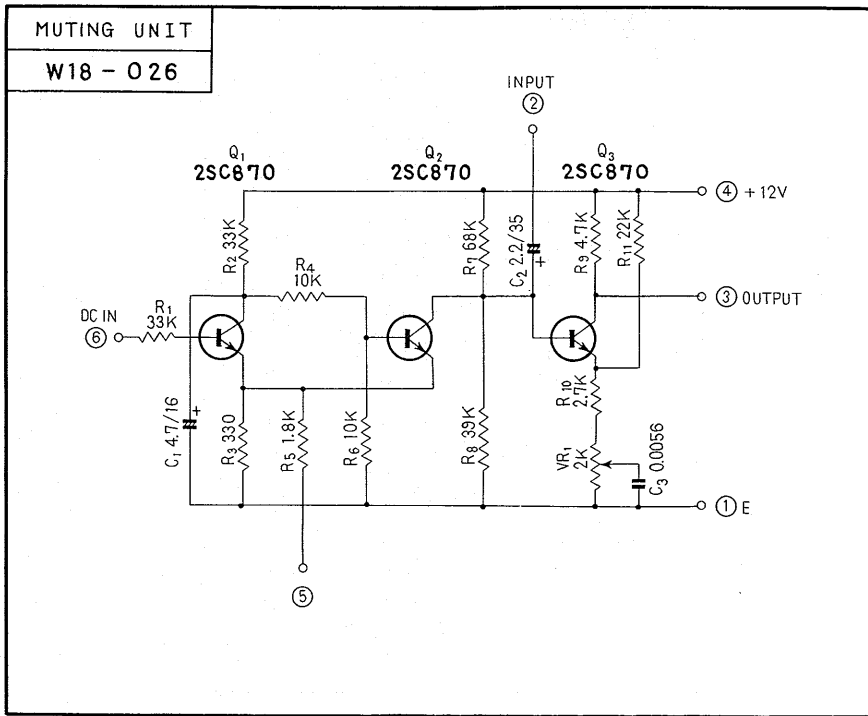

HEAD AMP UNIT (W21-004)

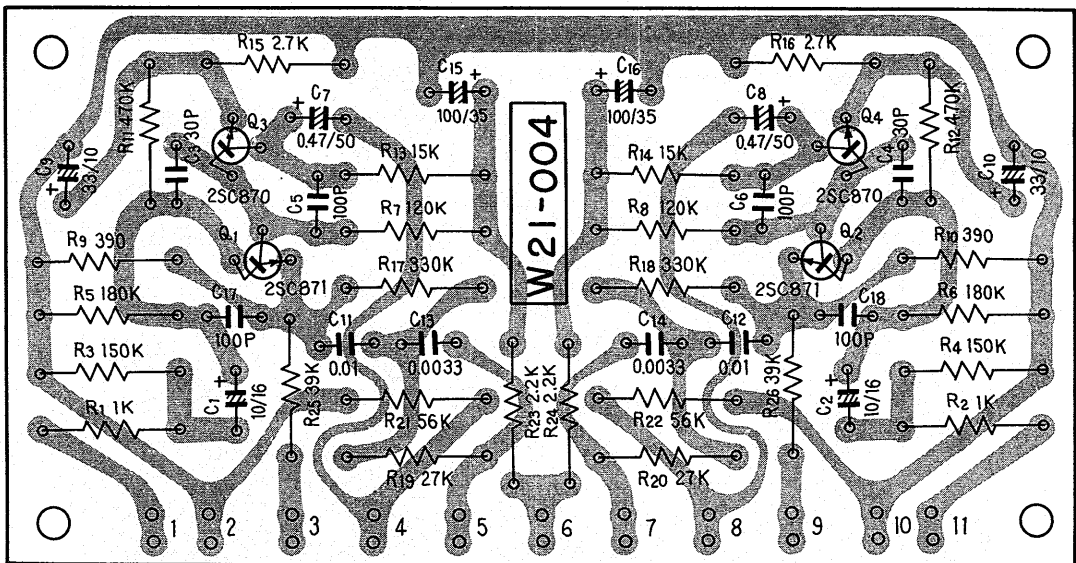
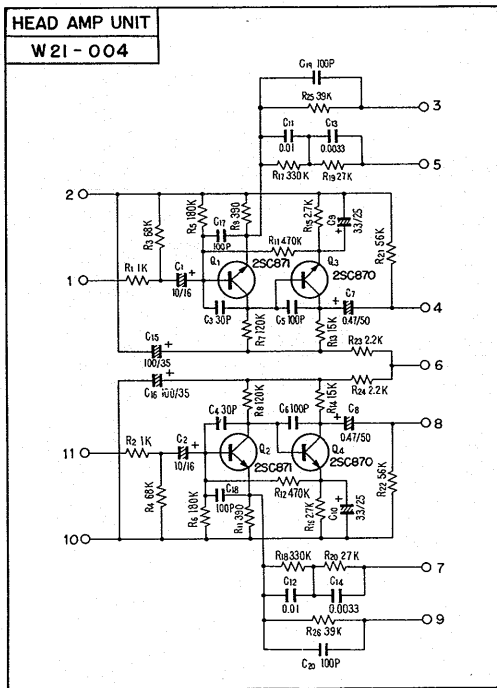

CONTROL AMP UNIT (W15-079)

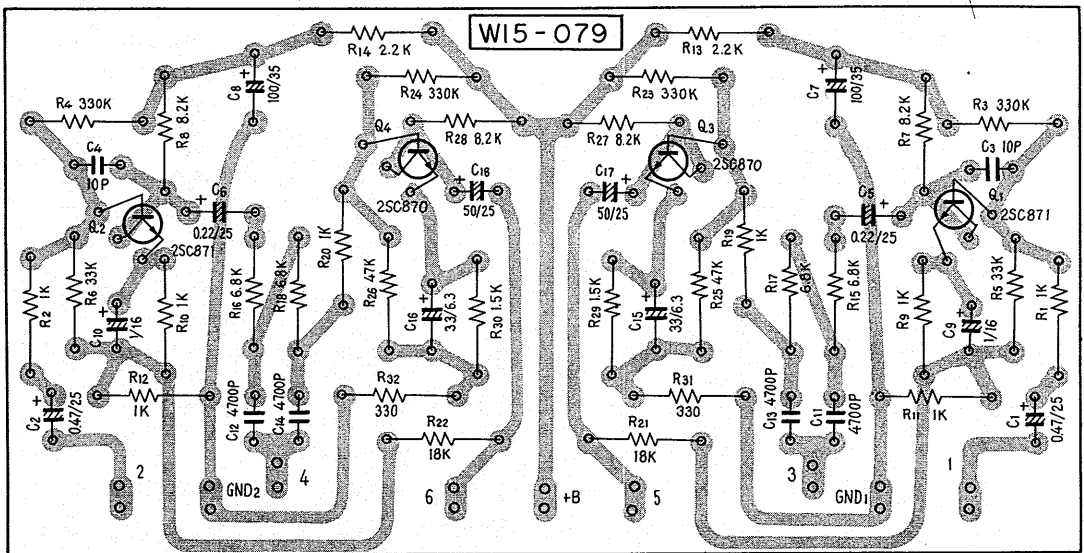
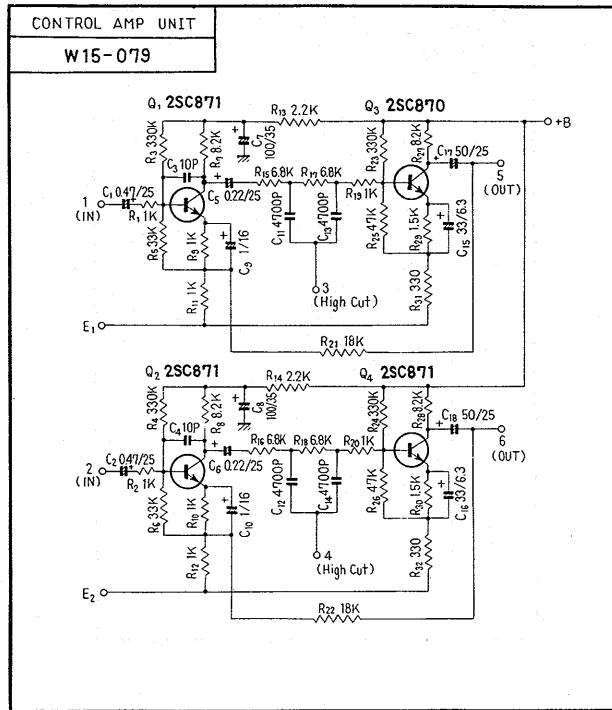

CONTROL UNIT (AWG-006)

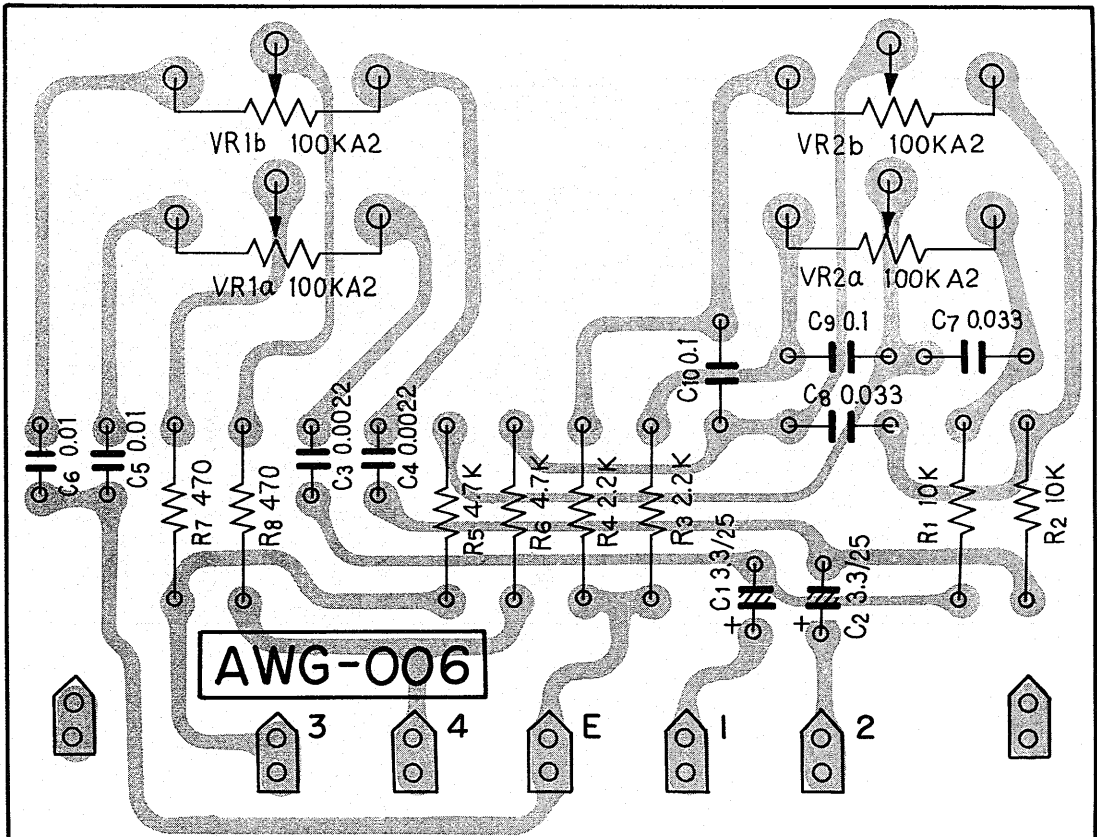
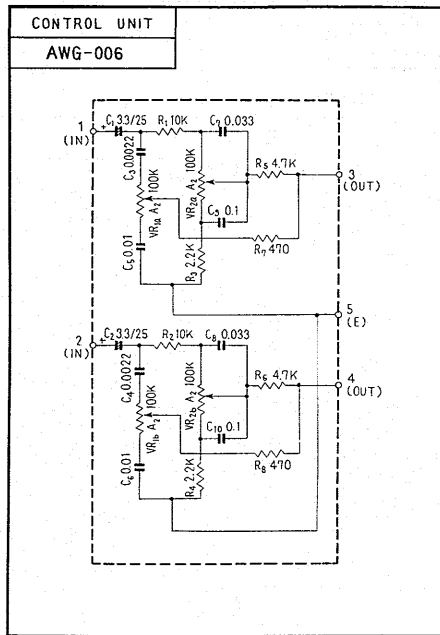

SWITCH UNIT (AWS-007)

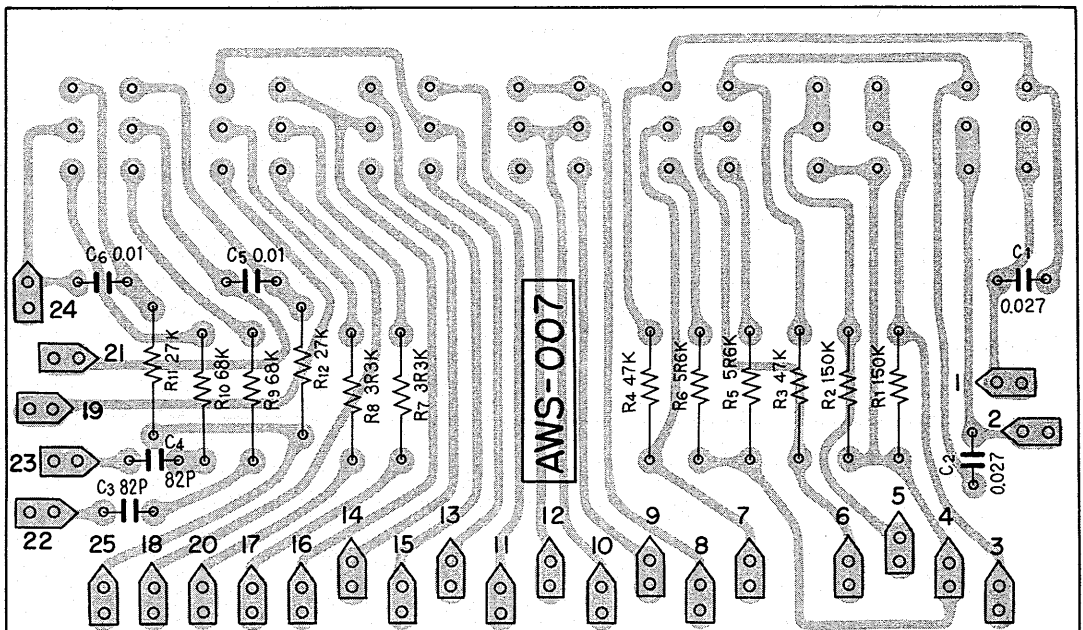
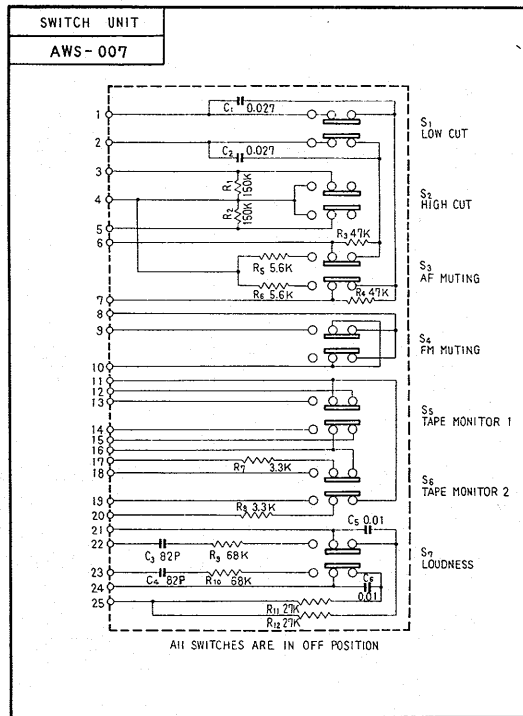

MAIN AMP UNIT (W23-002)

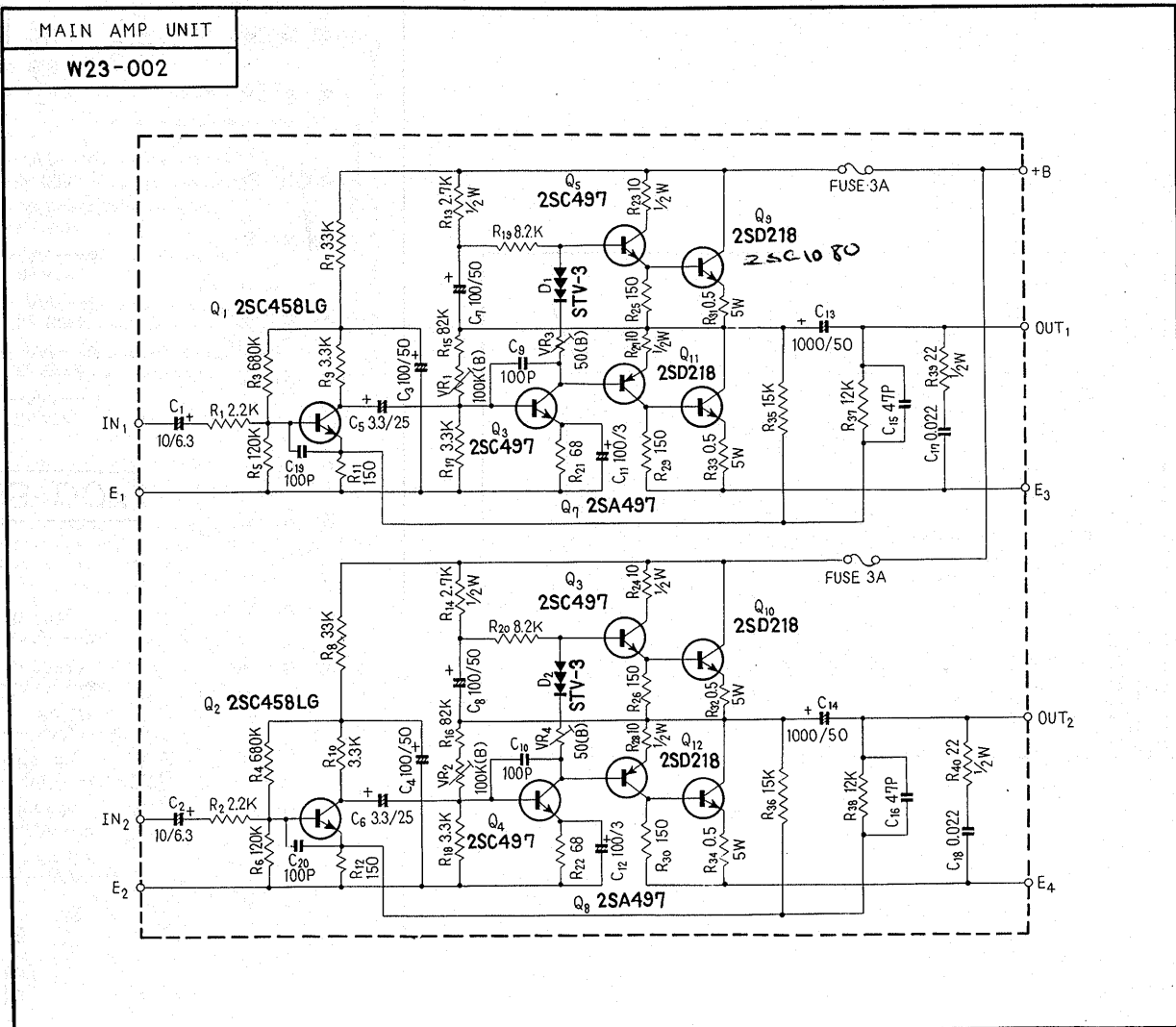

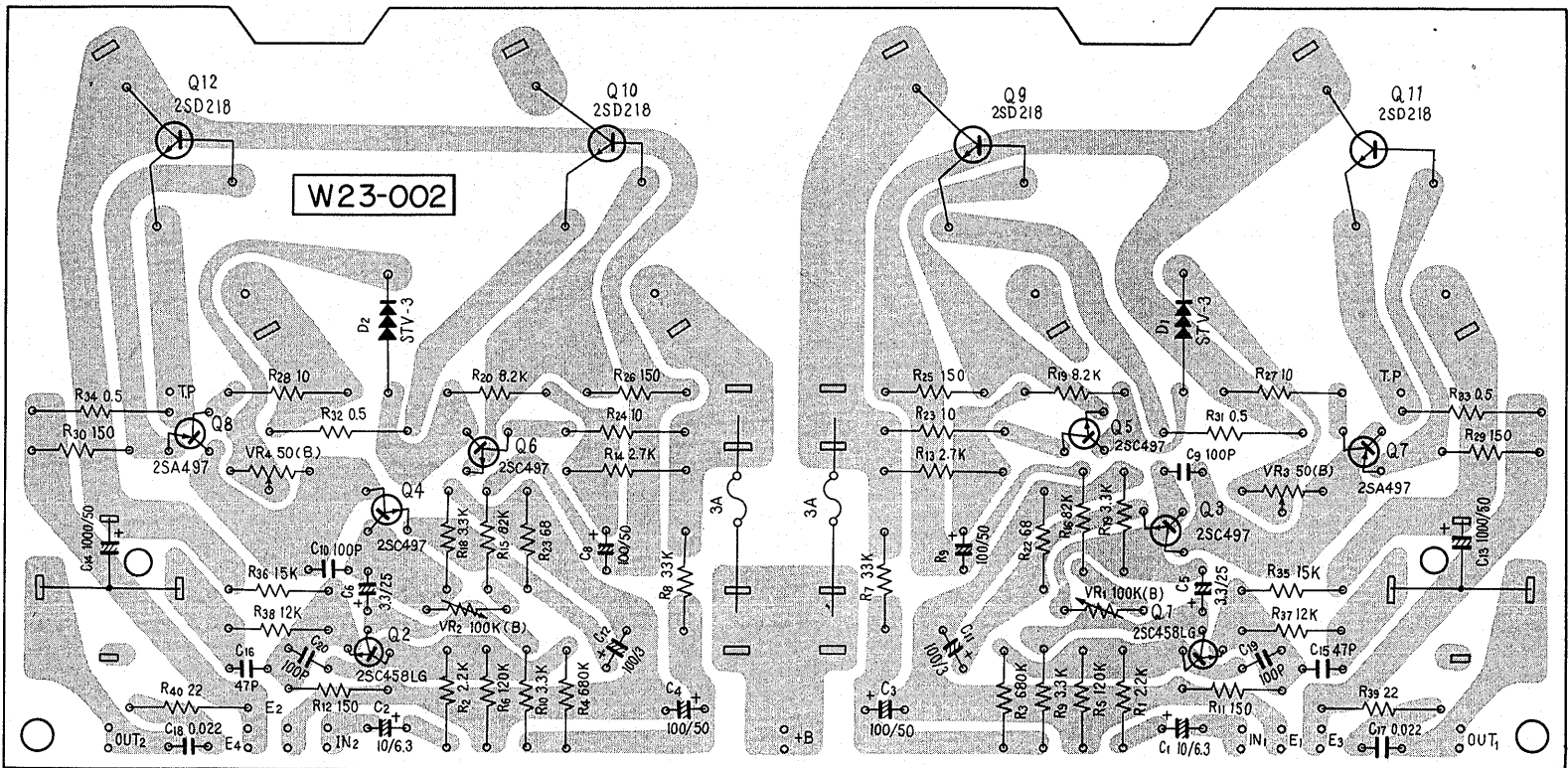

POWER SUPPLY UNIT (W16-026)

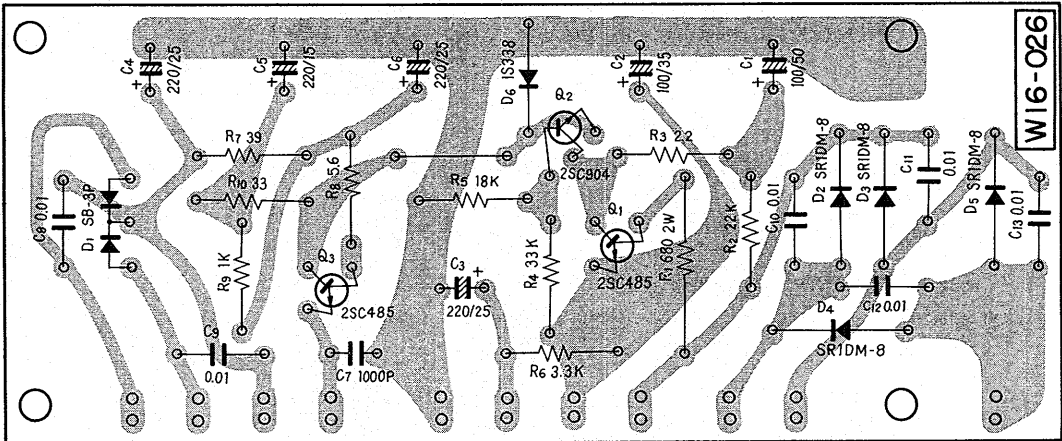
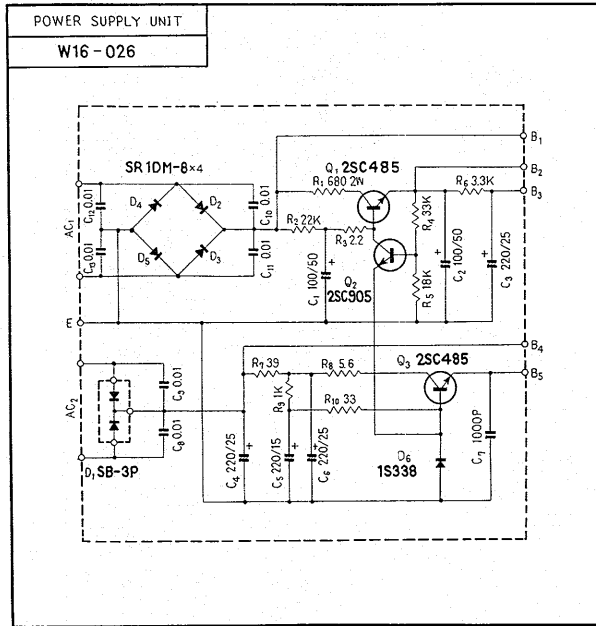

9 · PARTS LIST

MISCELLANEOUS

CAPACITORS

IN μ F UNLESS OTHERWISE NOTED, p: μ μ F.

Symbol	Description			Part No.
C1	Ceramic	0.01	DC 1.4kV	C43-003-0
C2	Ceramic	0.01	DC 1.4kV	C43-003-0
C3	Ceramic	0.01	DC 1.4kV	C43-003-0
C4	Electrolytic	3300	80V	ACH-005-0
C5	Electrolytic	1000	50V	C52-084-B
C6	Electrolytic	1000	50V	C52-084-B
C7	Electrolytic	4.7	16V	CEB 4R7P 16
C8	Ceramic	15p	50V	CCDSL 150K 50
C9	Ceramic	3p	50V	CCDSL 030D 50
C10	Mylar	0.001	50V	CQMA 102K 50
C11	Mylar	0.001	50V	CQMA 102K 50
C12	Ceramic	0.01	50V	CKDYF 103Z 50
C13	Ceramic	0.01	50V	CKDYF 103Z 50
C14	Ceramic	0.01	50V	CKDYF 103Z 50
C15	Ceramic	0.01	50V	CKDYF 103Z 50
C16	Mylar	0.047	400V	CQMA 473K 400
VC1	AM Tuning Capacitor			C64-030-0

RESISTORS

IN Ω , $\frac{1}{4}$ W UNLESS OTHERWISE NOTED, k: k Ω , M: M Ω .

Symbol	Description			Part No.
R1	Carbon film	470		RD $\frac{1}{4}$ PS 471K
R2	Carbon film	470	$\frac{1}{4}$ W	RD $\frac{1}{4}$ PS 471K
R3	Carbon film	47k		RD $\frac{1}{4}$ PS 473K
R4	Carbon film	47k		RD $\frac{1}{4}$ PS 473K
R5	Carbon film	100k		RD $\frac{1}{4}$ PS 104K
R6	Carbon film	100k		RD $\frac{1}{4}$ PS 104K
R7	Carbon film	6.8k		RD $\frac{1}{4}$ PS 682K
R8	Carbon film	6.8k		RD $\frac{1}{4}$ PS 682K
R9	Carbon film	100		RD $\frac{1}{4}$ PS 101K
R10	Wire wound	150	3W	RT3B 151K
R11	Wire wound	150	3W	RT3B 151K
R12	Wire wound	150	3W	RT3B 151K
R13	Wire wound	150	3W	RT3B 151K
R14	Carbon film	120k		RD $\frac{1}{4}$ PS 124K
R15	Carbon film	1.2k		RD $\frac{1}{4}$ PS 122K
R16	Carbon film	100k		RD $\frac{1}{4}$ PS 104K
R17	Carbon film	100k		RD $\frac{1}{4}$ PS 104K
R18	Carbon film	1.2k		RD $\frac{1}{4}$ PS 122K
R19	Carbon film	1.2k		RD $\frac{1}{4}$ PS 122K
R20	Carbon film	150k		RD $\frac{1}{4}$ PS 154K
R21	Carbon film	150k		RD $\frac{1}{4}$ PS 154K

POTENTIOMETERS

Symbol	Description	Part No.	
VR1	500k HB, dual, BALANCE	C85-048-B	
VR2	500k B, dual, VOLUME	C85-054-0	

SWITCHES

Symbol	Description	Part No.	
S1	Selector Switch	ASB-004-B	
S2	Mode Switch	S14-035-0	
S3	Speakers Switch	ASC-010-A	
S4	Power Switch	S11-016-A	
S5	Pre & Main Switch	S41-022-A	
S6	Line Voltage Selector	AKR-001-0	

COILS AND TRANSFORMER

Symbol	Description	Part No.	
L1	Choke Coil 100 μ H	T24-030-0	
L2	Choke Coil	T24-026-0	
	AM Ferrite Loopstick Antenna	T42-024-A	
	Power Transformer	T52-176-A	

OTHERS

Symbol	Description	Part No.	
	FM Front end	W11-028-E	
	FM IF Unit	W12-032-A	
	AM Tuner Unit	W14-015-A	
	MPX Unit	W13-026-C	
	Muting Unit	W18-026-B	
	Head Amp Unit	W21-004-0	
	Control Amp Unit	W15-079-0	
	Control Unit	AWG-006-0	
	Power Supply Unit	W16-026-C	
	Switch Unit	AWS-007-A	
	Main Amp Unit	W23-002-D	
	Front Panel Ass'y	ANB-054-B	
	Fuse 3A	E21-006-0	
	Dial Shaft Ass'y	AXA-007-A	
	Rubber Cushion	AEB-002-0	
	Wooden Case	AMM-003-E	
	Dial Glass	AAG-005-D	
	Dial Pointer	AAF-002-B	
	Signal Meter	AAW-001-A	
	Tuning Meter	AAW-002-A	
	Knob for Push button switch	A19-077-0	
	Knob for Tuning	AAA-001-B	
	Knob for Selector and Volume	AAB-003-A	
	Knob for Power, Speakers, Bass, Treble, Mode and Balance	AAB-001-0	
	16P Input Terminal Board	AKB-002-0	
	4P Input Terminal Board	K22-010-E	
	1P Input Terminal Board	K21-005-C	
	Antenna Input Terminal Board	K11-043-A	

Symbol	Description	Part No.	
	Pilot Lamp for Dial Glass	E22-017-0	
	Pilot Lamp for Tuning and Signal Meters	E22-002-0	
	Pilot Lamp for Program Indicator	E22-025-0	
	Pilot Lamp for FM Stereo Indicator	E22-015-C	
	Fuse 1.5A	E21-012-0	
	Fuse 3A	E21-022-0	
	Compound Part for REC Terminal	W52-004-0	
	Spare AC Outlet	K82-014-0	
	Speaker Socket	K72-028-0	
	Microphone Jack	K72-024-0	
	Headphones Jack	K72-026-0	
	Pilot Lamp (for meters) Socket	K41-002-B	
	Pilot Lamp (for dial glass) Socket	K91-005-A	
	Tape Rec/P.B. Connector (DIN)	K93-003-B	
	AC Power Cord	D11-002-B	
	Operating Instructions	ARB-007-0	
	FM Indoor Antenna	D52-013-0	
	⊕ Machine Screw M4 x 30		
	Screw for Grounding	B11-012-A	
	Washer (Square)	M52-010-0	
	Packing Case	AHD-021-0	
	Protector (styren)	AHA-004-A	
	AM Antenna Holder Ass'y	AXB-001-0	
	4P Ground Terminal	K13-047-0	
	Short Pin Plug	K71-028-0	
	Pin plug	K72-015-A	
	Speaker Plug	K72-007-B	

FM IF UNIT (W12-032)

CAPACITORS

Symbol	Description	Part No.	
C1	Ceramic 0.01 50V	CKDYF 103Z 50	
C2	Ceramic 0.01 50V	CKDYF 103Z 50	
C3	Ceramic 0.01 50V	CKDYF 103Z 50	
C4	Ceramic 0.01 50V	CKDYF 103Z 50	
C5	Ceramic 10p 50V	CCDSL 100K 50	
C6	Mylar 0.1 50V	CQMA 104K 50	
C7	Ceramic 10p 50V	CCDSL 100K 50	
C8	Ceramic 0.01 50V	CKDYF 103Z 50	
C9	Ceramic 0.01 50V	CKDYF 103Z 50	
C10	Ceramic 10p 50V	CCDSL 100K 50	
C11	Ceramic 0.01 50V	CKDYF 103Z 50	
C12	Ceramic 0.01 50V	CKDYF 103Z 50	
C13	Ceramic 3p 50V	CCDSL 030C 50	
C14	Electrolytic 1 50V	CEA 010P 50	
C15	Ceramic 0.01 50V	CKDYF 103Z 50	
C16	Ceramic 0.01 50V	CKDYF 103Z 50	
C17	Ceramic 100p 50V	CCDSL 101K 50	
C18	Ceramic 0.01 50V	CKDYF 103Z 50	
C19	Ceramic 0.01 50V	CKDYF 103Z 50	
C20	Electrolytic 4.7 16V	CEA 4R7P 16	
C21	Ceramic 100p 50V	CCDSL 101K 50	
C22	Electrolytic 4.7 16V	CEA 4R7P 16	
C23	Electrolytic 1 25V	CSYA 010M 25	

RESISTORS

Symbol	Description	Part No.
R1	Carbon film 820	RD¼PS 821K
R2	Carbon film 10k	RD¼PS 103K
R3	Carbon film 47k	RD¼PS 473K
R4	Carbon film 100	RD¼PS 101K
R5	Carbon film 1k	RD¼PS 102K
R6	Carbon film 47k	RD¼PS 473K
R7	Carbon film 1k	RD¼PS 102K
R8	Carbon film 47k	RD¼PS 473K
R9	Carbon film 100	RD¼PS 101K
R10	Carbon film 6.8k	RD¼PS 682K
R11	Carbon film 2.7k	RD¼PS 272K
R12	Carbon film 22k	RD¼PS 223K
R13	Carbon film 100	RD¼PS 101K
R14	Carbon film 22k	RD¼PS 223K
R15	Carbon film 220k	RD¼PS 224K
R16	Carbon film 820	RD¼PS 821K

SEMICONDUCTORS

Symbol	Description	Part No.
Q1	TA7060P-R or W IC	
Q2	TA7060P-R or W IC	
Q3	TA7060P-W IC	
Q4	TA7060P-W IC	
D1	1S188 FM-1 or 1N60 Diode	
D2	1S188 FM-1 or 1N60 Diode	
D3	1S188 FM-1 or 1N60 Diode	
D4	1S188 FM-1 or 1N60 Diode	
D5	1S188 FM-1 or 1N60 Diode	
D6	1S188 FM-1 or 1N60 Diode	

COILS AND TRANSFORMERS

Symbol	Description	Part No.
L1	RF Choke Coil	T24-028-A
L2	RF Choke Coil	T24-028-A
T1	FM IF Transformer	T73-041-0
T2	FM IF Transformer	T73-041-0
T3	FM IF Transformer	T73-041-0
T4	FM IF Transformer	T74-014-0

COMPOUND PART

Symbol	Description	Part No.
	for FM Detector Circuit	W53-040-0

MPX UNIT (W13-026)

CAPACITORS

Symbol	Description	Part No.
C1	Electrolytic 2.2 50V	CEA 2R2P 50
C2	Electrolytic 10 16V	CEA 100P 16
C3	Styrol 3300p 50V	C15-011-0
C4	Electrolytic 3.3 25V	CEA 3R3P 25
C5	Mylar 0.15 50V	CQMA 154K 50
C6	Mylar 2200p 50V	CQMA 222K 50
C7	Mylar 2200p 50V	CQMA 222K 50
C8	Electrolytic 0.47 25V	CSSA R47M 25
C9	Electrolytic 0.47 25V	CSSA R47M 25
C10	Mylar 1500p 50V	CQMA 152K 50
C11	Mylar 1500p 50V	CQMA 152K 50
C12	Ceramic 300p 50V	CCDSL 301K 50

RESISTORS

Symbol	Description	Part No.
R1	Carbon film 6.8k	RD¼PS 682K
R2	Carbon film 4.7k	RD¼PS 472K
R3	Carbon film 39k	RD¼PS 393K
R4	Carbon film 4.7k	RD¼PS 472K
R5	Carbon film 47k	RD¼PS 473K
R6	Carbon film 47	RD¼PS 470K
R7	Carbon film 2.2k	RD¼PS 222K
R8	Carbon film 15k	RD¼PS 153K
R9	Carbon film 100	RD¼PS 101K
R10	Carbon film 330	RD¼PS 331K
R11	Carbon film 33k	RD¼PS 333K
R12	Carbon film 10k	RD¼PS 103K
R13	Carbon film 10k	RD¼PS 103K
R14	Carbon film 470	RD¼PS 471K
R15	Carbon film 33k	RD¼PS 333K
R16	Carbon film 2.7k	RD¼PS 272K
R17	Carbon film 1.2k	RD¼PS 122K
R18	Carbon film 2.7k	RD¼PS 272K
R19	Carbon film 1.2k	RD¼PS 122K
R20	Carbon film 10k	RD¼PS 103K
R21	Carbon film 10k	RD¼PS 103K
R22	Carbon film 1k	RD¼PS 102K
R23	Carbon film 15k	RD¼PS 153K
R24	Carbon film 15k	RD¼PS 153K
R26	Carbon film 330	RD¼PS 331K
R27	Carbon film 1k	RD¼PS 102K
R28	Carbon film 33k	RD¼PS 333K
R29	Carbon film 33k	RD¼PS 333K

SEMICONDUCTORS

Symbol	Description	Part No.
Q1	2SC870-F or E Transistor	
Q2	2SC711-F or E Transistor	
Q3	2SC711-F or E Transistor	
Q4	2SC711-F or E Transistor	
Q5	2SC711-F or E Transistor	
Q6	CA3054 IC	
D1	1S188 FM-1 Diode	
D2	1S188 FM-1 Diode	

COILS AND TRANSFORMERS

Symbol	Description	Part No.
L1	19kHz Coil	T75-023-0
T1	MPX Transformer	T75-026-0
LPF1	38kHz Filter	T75-015-A
LPF2	38kHz Filter	T75-015-A

AM TUNER UNIT (W14-015)

CAPACITORS

Symbol	Description	Part No.
C1	Ceramic 0.04 25V	CKDYF 403Z 25
C2	Electrolytic 10 16V	CEA 100P 16
C3	Ceramic 0.04 25V	CKDYF 403Z 25
C4	Ceramic 0.04 25V	CKDYF 403Z 25
C5	Electrolytic 22 16V	CEA 220P 16
C6	Ceramic 0.04 25V	CKDYF 403Z 25
C7	Ceramic 0.04 25V	CKDYF 403Z 25
C8	Ceramic 0.04 25V	CKDYF 403Z 25
C9	Ceramic 0.04 25V	CKDYF 403Z 25
C10	Mylar 0.01 50V	CQMA 103K 50
C11	Styrol 410p 50V	COSA 411K 50
C12	Ceramic 0.04 25V	CKDYF 403Z 25
C13	Electrolytic 10 50V	CEA 100P 50
C14	Ceramic 0.02 25V	CKDYF 203Z 25
C15	Ceramic 0.04 25V	CKDYF 403Z 25
C16	Ceramic 0.04 25V	CKDYF 403Z 25
C17	Ceramic 0.04 25V	CKDYF 403Z 25
C18	Ceramic 47p 50V	CCDSL 470K 50
C19	Ceramic 0.04 25V	CKDYF 403Z 25
C20	Mylar 0.0047 50V	CQMA 472K 50
C21	Mylar 0.0047 50V	CQMA 472K 50
C22	Electrolytic 0.47 50V	CEA R47P 50
C23	Electrolytic 220 10V	CEA 221P 10
C24	Ceramic 0.04 25V	CKDYF 403Z 25
C25	Electrolytic 100 16V	CEA 101P 16

RESISTORS

Symbol	Description	Part No.
R1	Carbon film 22k	RD¼PS 223K
R2	Carbon film 15k	RD¼PS 153K
R3	Carbon film 470	RD¼PS 471K
R4	Carbon film 100	RD¼PS 101K
R5	Carbon film 2.2k	RD¼PS 222K
R6	Carbon film 10k	RD¼PS 103K
R7	Carbon film 3.3k	RD¼PS 332K
R8	Carbon film 470	RD¼PS 471K
R9	Carbon film 1k	RD¼PS 102K
R10	Carbon film 1k	RD¼PS 102K
R11	Carbon film 4.7k	RD¼PS 472K
R12	Carbon film 27k	RD¼PS 273K
R13	Carbon film 1k	RD¼PS 102K
R14	Carbon film 68	RD¼PS 680K
R15	Carbon film 4.7k	RD¼PS 472K
R16	Carbon film 100k	RD¼PS 104K
R17	Carbon film 27k	RD¼PS 273K
R18	Carbon film 1k	RD¼PS 102K
R19	Carbon film 150k	RD¼PS 154K
R20	Carbon film 4.7k	RD¼PS 472K
R21	Carbon film 4.7k	RD¼PS 472K
R22	Carbon film 22k	RD¼PS 223K
R23	Carbon film 470	RD¼PS 471K
R24	Carbon film 470	RD¼PS 471K
R25	Carbon film 100	RD¼PS 101K
R26	Carbon film 3.3k	RD¼PS 332K
R27	Carbon film 6.8k	RD¼PS 682K
R28	Carbon film 100	RD¼PS 101K
R29	Carbon film 3.9k	RD¼PS 392K
R30	Carbon film 4.7k	RD¼PS 472K

SEMICONDUCTORS

Symbol	Description	Part No.	
Q1	2SC382 Transistor		
Q2	2SC460 Transistor		
Q3	2SC460 Transistor		
Q4	2SC460 Transistor		
Q5	2SC460 Transistor		
D1	1S188 FM-1 Diode		
D2	1S188 FM-1 Diode		

COILS AND TRANSFORMERS

Symbol	Description	Part No.	
T1	MW RF Coil	T41-008-0	
T2	MW OSC Coil	T43-007-0	
T3	AM IF Transformer	T71-025-A	
T4	AM IF Transformer	T71-025-A	
T5	AM IF Transformer	T72-017-0	

MUTING UNIT (W18-026)

CAPACITORS

Symbol	Description	Part No.	
✓C1	Electrolytic 4.7 16V	CEA 4R7P 16	
✓C2	Electrolytic 2.2 35V	CEA 2R2P 35	2.2 50V

RESISTORS

Symbol	Description	Part No.	
R1	Carbon film 33k	RD¼PS 333K	
R2	Carbon film 33k	RD¼PS 333K	
R3	Carbon film 330	RD¼PS 331K	
R4	Carbon film 10k	RD¼PS 103K	
R5	Carbon film 5.6k	RD¼PS 562K	
R6	Carbon film 10k	RD¼PS 103K	
R7	Carbon film 82k	RD¼PS 823K	
R8	Carbon film 33k	RD¼PS 333K	
R9	Carbon film 4.7k	RD¼PS 472K	
R10	Carbon film 2.7k	RD¼PS 272K	
R11	Carbon film 22k	RD¼PS 223K	

SEMICONDUCTORS

Symbol	Description	Part No.	
Q1	2SC870 Transistor		
Q2	2SC870 Transistor		
Q3	2SC870 Transistor		

HEAD AMP UNIT (W21-004)

CAPACITORS

Symbol	Description	Part No.	
C1	Electrolytic 10 16V	CEA 100P 16	
C2	Electrolytic 10 16V	CEA 100P 16	
C3	Ceramic 30p 50V	CCDSL 300K 50	
C4	Ceramic 30p 50V	CCDSL 300K 50	
C5	Ceramic 100p 50V	CCDSL 101K 50	
C6	Ceramic 100p 50V	CCDSL 101K 50	
C7	Electrolytic 0.47 50V	CEA R47P 50	
C8	Electrolytic 0.47 50V	CEA R47P 50	
C9	Electrolytic 3.3 25V	CEA 3R3P 25	
C10	Electrolytic 3.3 25V	CEA 3R3P 25	
C11	Mylar 0.01 50V	CQMA 103M 50	
C12	Mylar 0.01 50V	CQMA 103M 50	
C13	Mylar 0.0033 50V	CQMA 332M 50	
C14	Mylar 0.0033 50V	CQMA 332M 50	
✓C15	Electrolytic 100 35V	CEA 101P 35 ✓	
✓C16	Electrolytic 100 35V	CEA 101P 35 ✓	
C17	Ceramic 100p 50V	CCDSL 101K 50	
C18	Ceramic 100p 50V	CCDSL 101K 50	
C19	Ceramic 100p 50V	CCDSL 101K 50	
C20	Ceramic 100p 50V	CCDSL 101K 50	

RESISTORS

Symbol	Description	Part No.	
R1	Carbon film 1k	RD¼PS 102K	
R2	Carbon film 1k	RD¼PS 102K	
R3	Carbon film 68k	RD¼PS 683K	
R4	Carbon film 68k	RD¼PS 683K	
R5	Carbon film 180k	RD¼PS 184K	
R6	Carbon film 180k	RD¼PS 184K	
R7	Carbon film 120k	RD¼PS 124K	
R8	Carbon film 120k	RD¼PS 124K	
R9	Carbon film 390	RD¼PS 391K	
R10	Carbon film 390	RD¼PS 391K	
R11	Carbon film 470k	RD¼PS 474K	
R12	Carbon film 470k	RD¼PS 474K	
R13	Carbon film 15k	RD¼PS 153K	
R14	Carbon film 15k	RD¼PS 153K	
R15	Carbon film 2.7k	RD¼PS 272K	
R16	Carbon film 2.7k	RD¼PS 272K	
R17	Carbon film 330k	RD¼PS 334K	
R18	Carbon film 330k	RD¼PS 334K	
R19	Carbon film 27k	RD¼PS 273K	
R20	Carbon film 27k	RD¼PS 273K	
R21	Carbon film 56k	RD¼PS 563K	
R22	Carbon film 56k	RD¼PS 563K	
R23	Carbon film 2.2k	RD¼PS 222K	
R24	Carbon film 2.2k	RD¼PS 222K	
R25	Carbon film 39k	RD¼PS 393K	
R26	Carbon film 39k	RD¼PS 393K	

SEMICONDUCTORS

Symbol	Description	Part No.	
Q1	2SC871-E or F Transistor		
Q2	2SC871-E or F Transistor		
Q3	2SC870 Transistor		
Q4	2SC870 Transistor		

CONTROL AMP UNIT (W15-079)

CAPACITORS

Symbol	Description	Part No.	
✓C1	Electrolytic 0.47 25V	CSYA R47M 25	
✓C2	Electrolytic 0.47 25V	CSYA R47M 25	
C3	Ceramic 10p 50V	CCDSL 100K 50	
C4	Ceramic 10p 50V	CCDSL 100K 50	
✓C5	Electrolytic 0.22 25V	CSYA R22M 25	
✓C6	Electrolytic 0.22 25V	CSYA R22M 25	
✓C7	Electrolytic 100 35V	CEA 101P 35	
✓C8	Electrolytic 100 35V	CEA 101P 35	
✓C9	Electrolytic 1 25V	CSYA 010M 25	
✓C10	Electrolytic 1 25V	CSYA 010M 25	
C11	Mylar 0.0047 50V	CQMA 472K 50	
C12	Mylar 0.0047 50V	CQMA 472K 50	
C13	Mylar 0.0047 50V	CQMA 472K 50	
C14	Mylar 0.0047 50V	CQMA 472K 50	
✓C15	Electrolytic 33 10V	CEA 330P 10	
✓C16	Electrolytic 33 10V	CEA 330P 10	
✓C17	Electrolytic 50 25V	CEA 500P 25	
✓C18	Electrolytic 50 25V	CEA 500P 25	

RESISTORS

Symbol	Description	Part No.	
R1	Carbon film 1k	RD¼PS 102KNL	
R2	Carbon film 1k	RD¼PS 102KNL	
R3	Carbon film 330k	RD¼PS 334KNL	
R4	Carbon film 330k	RD¼PS 334KNL	
R5	Carbon film 33k	RD¼PS 333KNL	
R6	Carbon film 33k	RD¼PS 333KNL	
R7	Carbon film 8.2k	RD¼PS 822KNL	
R8	Carbon film 8.2k	RD¼PS 822KNL	
R9	Carbon film 1k	RD¼PS 102KNL	
R10	Carbon film 1k	RD¼PS 102KNL	
R11	Carbon film 1k	RD¼PS 102KNL	
R12	Carbon film 1k	RD¼PS 102KNL	
R13	Carbon film 2.2k	RD¼PS 222K	
R14	Carbon film 2.2k	RD¼PS 222K	
R15	Carbon film 6.8k	RD¼PS 682K	
R16	Carbon film 6.8k	RD¼PS 682K	
R17	Carbon film 6.8k	RD¼PS 682K	
R18	Carbon film 6.8k	RD¼PS 682K	
R19	Carbon film 1k	RD¼PS 102KNL	
R20	Carbon film 1k	RD¼PS 102KNL	
R21	Carbon film 18k	RD¼PS 183K	
R22	Carbon film 18k	RD¼PS 183K	
R23	Carbon film 330k	RD¼PS 334KNL	
R24	Carbon film 330k	RD¼PS 334KNL	
R25	Carbon film 47k	RD¼PS 473K	
R26	Carbon film 47k	RD¼PS 473K	
R27	Carbon film 8.2k	RD¼PS 822KNL	
R28	Carbon film 8.2k	RD¼PS 822KNL	
R29	Carbon film 1.5k	RD¼PS 152K	
R30	Carbon film 1.5k	RD¼PS 152K	
R31	Carbon film 330	RD¼PS 331K	
R32	Carbon film 330	RD¼PS 331K	

SEMICONDUCTORS

Symbol	Description	Part No.	
Q1	2SC871-BL Transistor		
Q2	2SC871-BL Transistor		
Q3	2SC870-GR or BL Transistor		
Q4	2SC870-GR or BL Transistor		

CONTROL UNIT (AWG-006)

CAPACITORS

Symbol	Description	Part No.	
✓C1	Electrolytic 3.3 25V	CSSA 3R3M 25	
✓C2	Electrolytic 3.3 25V	CSSA 3R3M 25	
C3	Mylar 0.0022 50V	CQMA 222K 50	
C4	Mylar 0.0022 50V	CQMA 222K 50	
C5	Mylar 0.01 50V	CQMA 103K 50	
C6	Mylar 0.01 50V	CQMA 103K 50	
C7	Mylar 0.033 50V	CQMA 333K 50	
C8	Mylar 0.033 50V	CQMA 333K 50	
C9	Mylar 0.1 50V	CQMA 104K 50	
C10	Mylar 0.1 50V	CQMA 104K 50	

RESISTORS

Symbol	Description	Part No.	
R1	Carbon film 10k	RD½PS 103K	
R2	Carbon film 10k	RD½PS 103K	
R3	Carbon film 2.2k	RD½PS 222K	
R4	Carbon film 2.2k	RD½PS 222K	
R5	Carbon film 4.7k	RD½PS 472K	
R6	Carbon film 4.7k	RD½PS 472K	
R7	Carbon film 470	RD½PS 471K	
R8	Carbon film 470	RD½PS 471K	

POTENTIOMETERS

Symbol	Description	Part No.	
VR1	100k dual, Bass Control	C82-040-A	
VR2	100k dual, Treble Control	C82-040-A	

MAIN AMP UNIT (W23-002)

CAPACITORS

Symbol	Description			Part No.
✓ C1	Electrolytic	10	16V	CEA 100P 16
✓ C2	Electrolytic	10	16V	CEA 100P 16
✓ C3	Electrolytic	100	50V	CEA 101P 50
✓ C4	Electrolytic	100	50V	CEA 101P 50
✓ C5	Electrolytic	3.3	25V	CEA 3R3P 25
✓ C6	Electrolytic	3.3	25V	CEA 3R3P 25
✓ C7	Electrolytic	100	50V	CEA 101P 50
✓ C8	Electrolytic	100	50V	CEA 101P 50
C9	Ceramic	100p	50V	CCDSL 101K 50
C10	Ceramic	100p	50V	CCDSL 101K 50
✓ C11	Electrolytic	100	6V	CEA 101P 6
✓ C12	Electrolytic	100	6V	CEA 101P 6
C13	Electrolytic	1000	50V	C52-072-0
C14	Electrolytic	1000	50V	C52-072-0
C15	Ceramic	47p	50V	CCDSL 470K 50
C16	Ceramic	47p	50V	CCDSL 470K 50
C17	Mylar	0.022	50V	CQMA 223M 50
C18	Mylar	0.022	50V	CQMA 223M 50

RESISTORS

Symbol	Description			Part No.
R1	Carbon film	2.2k		RD¼PS 222K
R2	Carbon film	2.2k		RD¼PS 222K
R3	Carbon film	680k		RD¼PS 684K
R4	Carbon film	680k		RD¼PS 684K
R5	Carbon film	120k		RD¼PS 124K
R6	Carbon film	120k		RD¼PS 124K
R7	Carbon film	33k		RD¼PS 333K
R8	Carbon film	33k		RD¼PS 333K
R9	Carbon film	3.3k		RD¼PS 332K
R10	Carbon film	3.3k		RD¼PS 332K
R11	Carbon film	150		RD¼PS 151K
R12	Carbon film	150		RD¼PS 151K
R13	Carbon film	2.7k	½W	RD½PS 272K
R14	Carbon film	2.7k	½W	RD½PS 272K
R15	Carbon film	82k		RD¼PS 823K
R16	Carbon film	82k		RD¼PS 823K
R17	Carbon film	3.3k		RD¼PS 332K
R18	Carbon film	3.3k		RD¼PS 332K
R19	Carbon film	8.2k		RD¼PS 822K
R20	Carbon film	8.2k		RD¼PS 822K
R21	Carbon film	68		RD¼PS 680K
R22	Carbon film	68		RD¼PS 680K
R23	Carbon film	10	½W	RD½PS 100K
R24	Carbon film	10	½W	RD½PS 100K
R25	Carbon film	150		RD¼PS 151K
R26	Carbon film	150		RD¼PS 151K
R27	Carbon film	10	½W	RD½PS 100K
R28	Carbon film	10	½W	RD½PS 100K
R29	Carbon film	150		RD¼PS 151K
R30	Carbon film	150		RD¼PS 151K

Symbol	Description	Part No.	
R31	Wire wound 0.5 5W	RT5B 0R5K	
R32	Wire wound 0.5 5W	RT5B 0R5K	
R33	Wire wound 0.5 5W	RT5B 0R5K	
R34	Wire wound 0.5 5W	RT5B 0R5K	
R35	Carbon film 15k	RD $\frac{1}{4}$ PS 153K	
R36	Carbon film 15k	RD $\frac{1}{4}$ PS 153K	
R37	Carbon film 12k	RD $\frac{1}{4}$ PS 123K	
R38	Carbon film 12k	RD $\frac{1}{4}$ PS 123K	
R39	Carbon film 22 $\frac{1}{2}$ W	RD $\frac{1}{2}$ PS 220K	
R40	Carbon film 22 $\frac{1}{2}$ W	RD $\frac{1}{2}$ PS 220K	

SEMICONDUCTORS

Symbol	Description	Part No.	
Q1	2SC458LG-B or C Transistor		
Q2	2SC458LG-B or C Transistor		
Q3	2SC497-O or Y Transistor		
Q4	2SC497-O or Y Transistor		
Q5	2SC497-O or Y Transistor		
Q6	2SC497-O or Y Transistor		
Q7	2SA497-O or Y Transistor		
Q8	2SA497-O or Y Transistor		
Q9	2SC1080-R Transistor		
Q10	2SC1080-R Transistor		
Q11	2SC1080-R Transistor		
Q12	2SC1080-R Transistor		
D1	STV-3 Varistor		
D2	STV-3 Varistor		

POTENTIOMETERS

Symbol	Description	Part No.	
VR1	100k, B, Semi-fixed	C92-042-0	
VR2	100k, B, Semi-fixed	C92-042-0	
VR3	50, B, Semi-fixed	C92-043-A	
VR4	50, B, Semi-fixed	C92-043-A	

POWER SUPPLY UNIT (W16-026)

CAPACITORS

Symbol	Description	Part No.	
✓C1	Electrolytic 100 50V	CEA 101P 50	
✓C2	Electrolytic 100 50V	CEA 101P 50	
✓C3	Electrolytic 100 35V	CEA 101P 35	
✓C4	Electrolytic 220 25V	CEA 221P 25	
✓C5	Electrolytic 220 15V	CEA 221P 15	
✓C6	Electrolytic 220 25V	CEA 221P 25	
C7	Mylar 0.001 50V	CQMA 102K 50	
C8	Ceramic 0.01 50V	CKDYF 103Z 50	
C9	Ceramic 0.01 50V	CKDYF 103Z 50	
C10	Ceramic 0.01 50V	CKDYF 103Z 50	
C11	Ceramic 0.01 50V	CKDYF 103Z 50	
C12	Ceramic 0.01 50V	CKDYF 103Z 50	
C13	Ceramic 0.01 500V	CKDYF 103Z 500	

RESISTORS

Symbol	Description	Part No.
R1	Metal Oxide 680 2W	RS2P 681K
R2	Carbon film 22k	RD¼PS 223K
R3	Carbon film 2.2k	RD¼PS 222K
R4	Carbon film 33k	RD¼PS 333K
R5	Carbon film 18k	RD¼PS 183K
R6	Carbon film 3.3k	RD¼PS 332K
R7	Carbon film 39	RD¼PS 390K
R8	Carbon film 5.6	RD¼PS 5R6K
R9	Carbon film 1k	RD¼PS 102K
R10	Carbon film 33	RD¼PS 330K

SEMICONDUCTORS

Symbol	Description	Part No.
Q1	2SC458-BL or Y Transistor	
Q2	2SC905 or 2SC904 Transistor	
Q3	2SC458-BL or Y Transistor	
D1	SB-3P Diode	
D2	SR3AM-8 or 1S1073 Diode	
D3	SR3AM-8 or 1S1073 Diode	
D4	SR3AM-8 or 1S1073 Diode	
D5	SR3AM-8 or 1S1073 Diode	
D6	WZ-130 Zener Diode	

SWITCH UNIT (AWS-007)

CAPACITORS

Symbol	Description	Part No.
C1	Mylar 0.027 50V	CQMA 273K 50
C2	Mylar 0.027 50V	CQMA 273K 50
C3	Ceramic 82p 50V	CCDSL 820K 50
C4	Ceramic 82p 50V	CCDSL 820K 50
C5	Mylar 0.01 50V	CQMA 103K 50
C6	Mylar 0.01 50V	CQMA 103K 50

RESISTORS

Symbol	Description	Part No.
R1	Carbon film 150k	RD¼PS 154K
R2	Carbon film 150k	RD¼PS 154K
R3	Carbon film 47k	RD¼PS 473K
R4	Carbon film 47k	RD¼PS 473K
R5	Carbon film 5.6k	RD¼PS 562K
R6	Carbon film 5.6k	RD¼PS 562K
R7	Carbon film 3.3k	RD¼PS 332K
R8	Carbon film 3.3k	RD¼PS 332K
R9	Carbon film 68k	RD¼PS 683K
R10	Carbon film 68k	RD¼PS 683K
R11	Carbon film 27k	RD¼PS 273K
R12	Carbon film 27k	RD¼PS 273K

SWITCH

Symbol	Description	Part No.
	Mini switch	ASG-006-0

10 • PACKING PROCEDURE AND PARTS

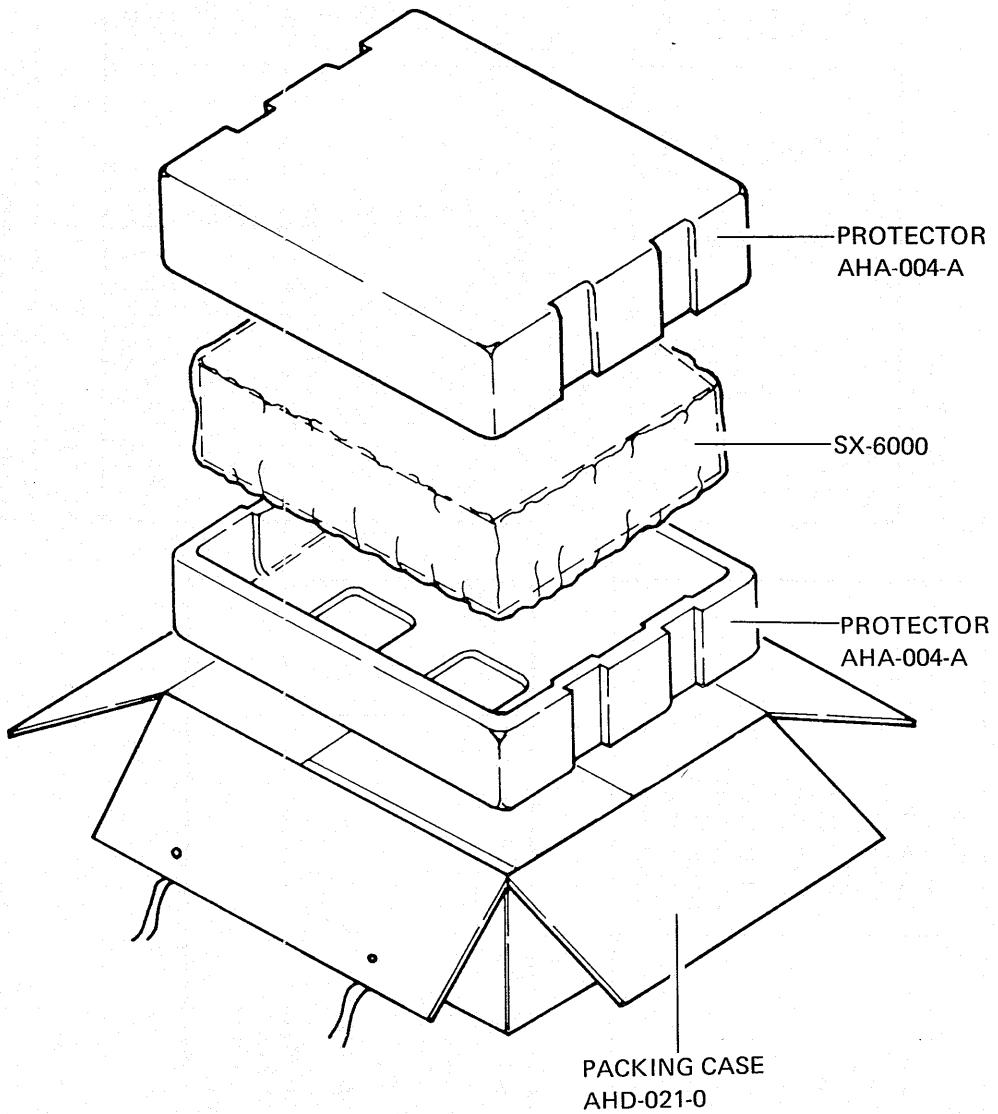

PIONEER ELECTRONIC CORPORATION

15-5, 4-Chome, Ohmori-nishi, Ohta-ku, Tokyo, Japan

U.S. PIONEER ELECTRONICS CORPORATION

178 Commerce Road, Carlstadt New Jersey 07072 U.S.A.

PIONEER ELECTRONIC (EUROPE) N.V.

Noorderlaan 83, 2030 Antwerp, Belgium